

Coalescing Compressed Air Filters



Balston Microfiber® Filter Assemblies

Balston Coalescing Compressed Air Filters protect your equipment and delicate instruments from the dirt, water, and oil usually found in compressed air. Balston Coalescing Filters remove these contaminants at a very high efficiency up to 99.99% for 0.01 micron particles and droplets. Liquid releases from the filter cartridge to an automatic drain as rapidly as it enters the filter. This allows a Balston Coalescing Filter to continue removing liquids for an unlimited time without loss of efficiency or flow capacity. Select 1/4" to 2" line filters come with a lifetime (20 year) warranty which guarantees the product against defects and other failures.



Product Features

- Remove 99.99% of 0.01 micron particles of oil, water, and dirt from compressed air and other gases
- Continuously trap and drain liquids
- Service flow ranges from a few SCFM to 40,000 SCFM
- Remove trace oil vapor with adsorbent cartridges
- Lifetime warranty (20 year) with select 1/4" to 2" line filters

Compressed Air Systems



Instrumentation and Automated Pneumatic Controls



Pneumatic Tools and Cylinders



Compressed Air Filters

International ISO Standards

Table taken from ISO8573 - 1

Class	Solid		Water		Oil	
	Maximum Particle Size (micron)	Maximum Concentration ppm (mg/m ³)	Maximum Pressure Dewpoint °F (°C)	Maximum Pressure Dewpoint °F (°C)	Maximum Concentration ppm (mg/m ³)	Maximum Concentration ppm (mg/m ³)
1	0.1	.08 (0.1)	-94 (-70)	-94 (-70)	.008 (0.01)	.008 (0.01)
2	1	.8 (1)	-40 (-40)	-40 (-40)	.08 (0.1)	.08 (0.1)
3	5	4.2 (5)	-4 (-20)	-4 (-20)	.83 (1)	.83 (1)
4	15	6.7 (8)	37 (+3)	37 (+3)	4.2 (5)	4.2 (5)
5	40	8.3 (10)	45 (+7)	45 (+7)	21 (25)	21 (25)
6	-	-	50 (+10)	50 (+10)	-	-

ISO Class Example **1** Solid **4** Water **1** Oil

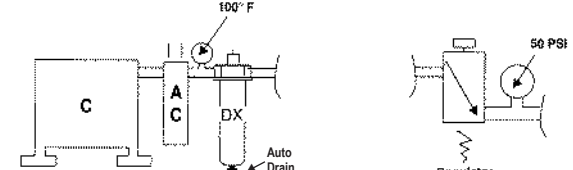
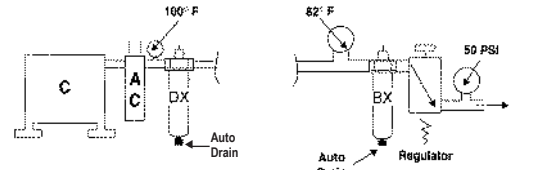
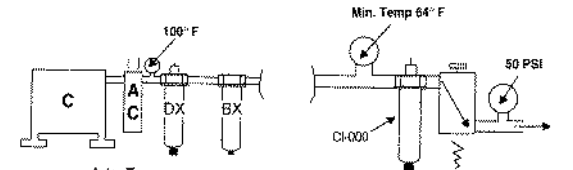
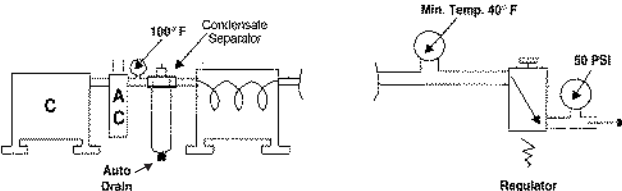
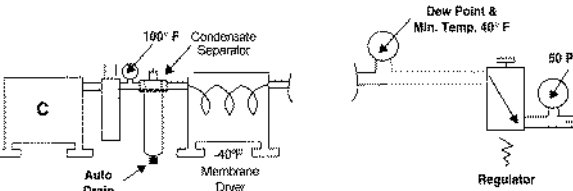
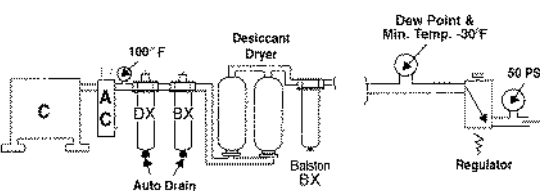
<p>ISO Class 2 2</p> <p>Any compressor with aftercooler and coalescer. Air intended for use with lubricated air tools, air motors, cylinders, shot blasting, non-frictional valves.</p>  <p>ADDITIONAL SPECS: CGA - G7.1 (Grades A & Ba1)</p>	<p>ISO Class 1 1</p> <p>Any compressor with aftercooler and 2-stage coalescing. Air intended for use as lubricated control valves, cylinders and parts blow-down.</p>  <p>ADDITIONAL SPECS: Mil. Std. 282 H.E.P.A., U.S.P.H.S. 3A accepted particles for milk.</p>
<p>ISO Class 1 1</p> <p>Any compressor with aftercooler, 2-stage coalescing and activated carbon filter. Air intended for use with general pneumatics systems.</p>  <p>ADDITIONAL SPECS: CGA - G7.1 (Grade C)</p>	<p>ISO Class 1 4 1</p> <p>Any compressor with aftercooler, 2-stage coalescing and refrigerated dryer for use with instrument quality air.</p>  <p>ADDITIONAL SPECS: CGA - G7.1 (Grade D & E) ISA S7.3, sFed. Std. 209 (Class 100)</p>
<p>ISO Class 2 2</p> <p>Any compressor with aftercooler, 2-stage coalescing, and a -40°F membrane air dryer. Air intended for use as industrial breathing air and decompression chambers.*</p>  <p>ADDITIONAL SPECS: O.S.H.A. 29CFR 1910.134 *CO Monitor required.</p>	<p>ISO Class 1 1 1</p> <p>Any 2-stage compressor with aftercooler, double coalescing and a regenerative type desiccant dryer. Air intended for use in applications involving critical instrumentation and high purity gases.</p>  <p>ADDITIONAL SPECS: CGA - G7.1 (Grade F)</p>

Note: In the pictorial examples shown above, the contribution of hydrocarbon vapors has not been taken into account in determining the OIL class category.

Compressed Air Filters

Compressed Air and Gas Water Separators

Protect your equipment from contamination:

Balston's new water separators have been designed for the efficient removal of bulk liquid contamination from compressed air. Today, many products are offered for the removal of bulk liquid from compressed air, however, these are often selected based only upon their initial purchase cost, with little or no regard for the separation efficiency they provide or the cost of operation throughout their life. Balston's water separators have been designed from the ground up with the key design focus on air flow management, separation efficiency at all flow conditions, minimal pressure losses and independently validated performance.



Separation Efficiency

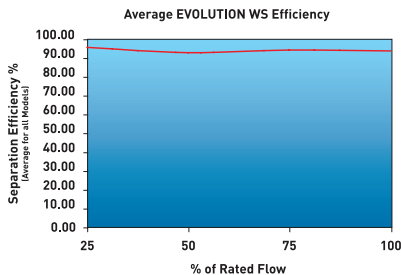

Tested with an Inlet challenge concentration of 33ml/m³hr and in accordance with ISO 8573.9. Performance shown is an average for all models in range. Individual model performance available on request.

Product Features: Applications:

- Tested in accordance with ISO 8573.9
- High liquid removal efficiencies at all flow conditions
- Float drain automatically expels condensate build-up
- Low pressure losses for low operational costs
- Suitable for variable flow compressors
- Works with all types of compressor and compressor condensate
- Low maintenance
- Bulk liquid removal at any point in a compressed air system
- Protection to membrane and desiccant dryer prefiltration
- Liquid removal from compressor inter-coolers / after-coolers
- Liquid separation within refrigeration dryers

Compressed Air Filters

Compressed Air and Gas Water Separators

Product Selection and Technical Data

Part Number	Port Size (inches) NPT	SCFM/Nm ³ /hr. at 100 psig (7 barg)	Max Operating Pressure psig (barg)	Max Operating Temp °F (°C)	Min Operating Temp °F (°C)
WS002N	1/4"	25 (42)	232 (16)	176 (80)	35 (1.7)
WS003N	3/8"	25 (42)	232 (16)	176 (80)	35 (1.7)
WS004N	1/2"	25 (4)	232 (16)	176 (80)	35 (1.7)
WSOH3N	3/8"	100 (170)	232 (16)	176 (80)	35 (1.7)
WSOH4N	1/2"	100 (170)	232 (16)	176 (80)	35 (1.7)
WS006N	3/4"	100 (170)	232 (16)	176 (80)	35 (1.7)
WS008N	1"	100 (170)	232 (16)	176 (80)	35 (1.7)
WSOH6N	3/4"	250 (425)	232 (16)	176 (80)	35 (1.7)
WSOH8N	1"	250 (425)	232 (16)	176 (80)	35 (1.7)
WS0010N	1-1/4"	250 (425)	232 (16)	176 (80)	35 (1.7)
WS0012N	1-1/2"	250 (425)	232 (16)	176 (80)	35 (1.7)
WSOH10N	1-1/4"	750 (1274)	232 (16)	176 (80)	35 (1.7)
WSOH12N	1-1/2"	750 (1274)	232 (16)	176 (80)	35 (1.7)
WS0016N	2"	750 (1274)	232 (16)	176 (80)	35 (1.7)
WS0020N	2-1/2"	1700 (2888)	232 (16)	176 (80)	35 (1.7)
WS0024N	3"	1700 (2888)	232 (16)	176 (80)	35 (1.7)

Flow/Pressure

Correction Factors

(to calculate flow rates below and above 100 PSIG use this table)

Line Pressure psig (barg)	Correction Factor
15 (1)	0.25
29 (2)	0.38
44 (3)	0.50
58 (4)	0.63
73 (5)	0.75
87 (6)	0.88
100 (7)	1.00
116 (8)	1.06
131 (9)	1.12
145 (10)	1.17
160 (11)	1.22
174 (12)	1.27
189 (13)	1.32
203 (14)	1.37
218 (15)	1.41
232 (16)	1.46

Dimensions and Weights

Part Number	Port Size (inches)	Dimensions inches (cm)			Weight lbs (kg)
		A	B	C	
WS002N	1/4"	3 (8)	7.2 (18)	6 (15)	1.3 (0.6)
WS003N	3/8"	3 (8)	7.2 (18)	6 (15)	1.3 (0.6)
WS004N	1/2"	3 (8)	7.2 (18)	6 (15)	1.3 (0.6)
WSOH3N	3/8"	3.8 (10)	9.3 (24)	7.9 (20)	2.4 (1.1)
WSOH4N	1/2"	3.8 (10)	9.3 (24)	7.9 (20)	2.4 (1.1)
WS006N	3/4"	3.8 (10)	9.3 (24)	7.9 (20)	2.4 (1.1)
WS008N	1"	3.8 (10)	9.3 (24)	7.9 (20)	2.4 (1.1)
WSOH6N	3/4"	5.1 (13)	10.8 (27)	9.2 (23)	4.8 (2.2)
WSOH8N	1"	5.1 (13)	10.8 (27)	9.2 (23)	4.8 (2.2)
WS0010N	1-1/4"	5.1 (13)	10.8 (27)	9.2 (23)	4.8 (2.2)
WS0012N	1-1/2"	5.1 (13)	10.8 (27)	9.2 (23)	4.8 (2.2)
WSOH10N	1-1/4"	6.7 (17)	17 (43)	15 (38)	11.2 (5.1)
WSOH12N	1-1/2"	6.7 (17)	17 (43)	15 (38)	11.2 (5.1)
WS0016N	2"	6.7 (17)	17 (43)	15 (38)	11.2 (5.1)
WS0020N	2-1/2"	8.1 (21)	19.9 (51)	17.5 (44)	22 (10.0)
WS0024N	3"	8.1 (21)	19.9 (51)	17.5 (44)	22 (10.0)

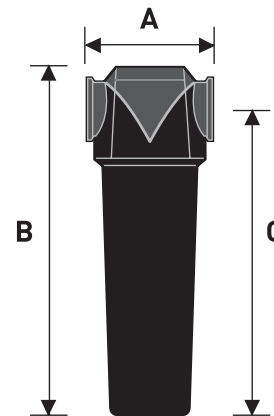

Compressed Air Filters

Filter Installation Recommendations

Recommendations for Typical Filter Installations

Selecting the proper location for a filter in a compressed air line is as important as selecting the proper filter. In most cases you will probably be able to base your own installation on these recommendations for typical installations.

Placing the Filter at the Compressor

The standard compressor installation consists of a prefilter (mounted on the compressor), a compressor, aftercooler, and a receiver. The Balston filter should be installed downstream from the receiver. In a system with an efficient aftercooler, the distance from the receiver to the filter is not important. Since the filter is usually maintained by the personnel responsible for the compressor, it is often convenient to install the filter downstream from the receiver. If there is no aftercooler, or the aftercooler is not efficient, coalescing filter be installed as close to the point(s) of use as possible.

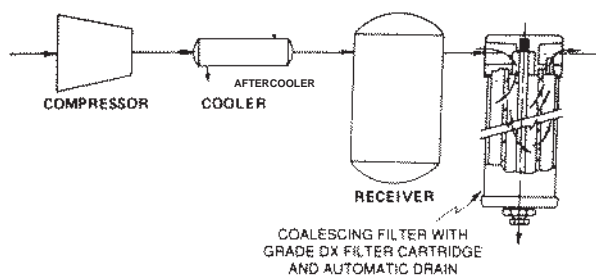

Compressor Filter Specifications

Microfibre Filter Cartridge	Grade DX
Filter Housing	Determine filter size from flow chart on page 3, but port size must be equal to or larger than the line size
Automatic Drain	Recommended
Differential Pressure Indicator	Recommended

Some compressor installations do not have an aftercooler (this is an undesirable situation). Air saturated with water vapor leaves a compressor at 240°F to 400°F (116°C to 204°C). Without an aftercooler, the air cools close to room temperature in the distribution lines and water condenses throughout the air distribution system. About two-thirds of the total water content of the air

will be condensed when the air has cooled to 100°F (38°C). A filter located just before the main air line branches into smaller distribution lines will remove most of the water load from the system. The filter requirements for the main line are described above; they are the same as for a system with an aftercooler. However, since the air will continue to cool in the distribution system, additional filters located at end-use points will be required to remove water condensed downstream from the main line filter.

How to Obtain a Trouble-Free Coalescer

The mechanism of coalescing leads to three important considerations in selecting and installing a coalescing filter:

- 1 The filter should be large enough to ensure that the air exits the filter at low velocity and does not carry over coalesced liquid. Proper sizing of a Balston coalescing filter is easily done by using the recommendations or the maximum flow rate data. There is no danger on oversizing the filter. A Balston coalescing filter is even more efficient at extremely low flow rates than at its maximum rated flow capacity.
- 2 To avoid liquid carryover, the coalesced liquid should not be allowed to build up in the filter housing above the level of the bottom of the filter tube. Rather than relying on operator attention to this easily-overlooked job, Parker Hannifin Corp. recommends automatic drains with all coalescing filters.
- 3 The flow direction through the Microfibre filter tube must be inside-to-outside to permit the liquid to drip from the outside of the tube to the drain in the filter housing. If installed outside-to-inside, the filter will at first function as a coalescing filter, but liquid will collect on the inside of the filter tube. Since there is no way of draining the liquid, the level will build up rapidly until it begins to be carried downstream by the air flow. The filter will work at removing liquids for a short time, and then not work at all. If the Balston coalescing filter exhibits these symptoms, reversing the flow direction will solve the problem.

Compressed Air Filters

Filter Cartridge and Housing Selection

Filter Cartridge Description

General purpose applications such as plant compressed air	Single stage filtration. Use a Grade DX filter cartridge
Instrument air and other critical air requirements	Two stage filtration is necessary. Use a Grade DX followed by a Grade BX filter cartridge. As a general rule, a Grade BX filter cartridge should not be used alone.
Removal of trace compressor oil vapor	For rare instances where even a trace amount of oil vapor can cause a problem, three stage filtration is necessary. Use a Grade DX followed by a Grade BX, and a type CI cartridge.

Physical Properties, Microfibre Filter Cartridges

Temperature Range	-150°F to 300°F (-100°C - 149°C)
Maximum Pressure Differential Across Filter, Inside-to-Outside Flow:	100 psi (7 bar)
Materials of Construction	Borosilicate glass microfibers with fluorocarbon resin binder. Resistant to water, all hydrocarbon and synthetic lubricants.

Retention Efficiency

Grade	Efficiency for 0.01 Micron Particles and Droplets
DX	93%
BX	99.99%

Balston Filter Cartridges

Balston provides two grades of coalescing filter cartridges, Grade DX and Grade BX. Singly or in tandem, these filters satisfy all requirements for removing liquid and solid contaminants from compressed air. Balston also has an activated carbon adsorbent CI-type cartridge for the removal of trace oil vapors from a compressed air line. The activated carbon cartridge is Grade 000.

How to Select the Filter Cartridge and Housing

- 1 Decide which grade(s) of filter cartridges fits the application (see selection boxes at left).
- 2 Select the filter housing with a port size equal to the line size where the filter is to be located.
- 3 For a new installation in which the line size has yet to be selected, determine the gas flow rate and pressure at the point where the filter will be located, and then refer to the flow chart on the reverse side of this data sheet. NOTE: The filter port size must be equal to or larger than the line size (when specified).

How to Order the Filter Assembly

- 1 Build your own custom filter assembly using the guideline matrix on Page 12 and specify your model number. Example: 1/2" filter with DPI and Auto Drain with Grade DX Filter = 6004N-01A-DX.
- 2 Each assembly is shipped with the filter cartridge installed. To order additional filter cartridges, indicate the model number of the cartridges, and the grade. Examples 050-05-DX, 050-05-BX. The grade used for Type CI cartridges is 000 (CI-100-12-000).

Note: Assemblies with CI Cartridges are shipped with the adsorbent cartridge wrapped separately. This shipping method prolongs the life of the cartridge.

Compressed Air Filters

Flow Rates

Filter Housing Model	Port Size	Filter Cartridge Grade	Flow rates SCFM, at 2 psi drop at indicated line pressure. Refer to Principal Specification for maximum pressure rating of each housing psig										
			2	20	40	80	100	125	150	200	250	400	650
A94A	1/4"	DX	4	9	13	24	29	36	43	55	67	—	—
A914, A914D, A914P		BX	1.2	2.4	4	7	8	9	12	15	17	—	—
2002	1/4"	DX	9	19	30	51	63	76	90	117	145	—	—
2003	3/8"	BX	3	8	11	21	25	31	36	47	58	—	—
2004	1/2"	CI	2	5	7	12	15	18	22	28	35	—	—
2104	1/2"	DX	19	41	65	113	137	166	196	257	316	—	—
		BX	9	19	30	51	63	76	90	117	145	—	—
		CI	6	12	19	32	39	48	56	73	90	—	—
2206	3/4"	DX	37	78	123	214	259	315	371	484	596	—	—
		BX	10	21	34	56	70	85	101	131	162	—	—
		CI	8	16	26	44	53	65	76	99	122	—	—
2208	1"	DX	55	115	181	314	380	463	546	711	877	—	—
		BX	11	23	37	64	77	94	111	144	178	—	—
		CI	10	20	32	56	67	82	96	125	154	—	—
2312	1 1/2"	DX	98	203	319	554	670	816	963	1254	1546	—	—
		BX	22	46	74	129	155	189	223	290	358	—	—
		CI	16	33	52	91	110	134	158	206	253	—	—
A15/80	2"	DX	160	333	525	908	1100	1340	1580	2060	2540	—	—
		BX	45	94	148	256	310	378	445	580	715	—	—
		CI	23	49	77	133	161	197	231	301	371	—	—
AKH-0280	3"	DX	364	760	1190	2060	2500	3045	3600	4680	5770	9030	14480
		BX	90	190	300	510	620	755	890	1160	1430	2240	3590
		CI	47	98	154	266	322	394	462	602	742	1160	1860
AKH-0480	4"	DX	740	1540	2430	4210	5100	6210	7300	9550	11750	18400	29480
		BX	180	380	590	1020	1240	1510	1780	2320	2860	4480	7180
		CI	94	196	308	632	644	780	920	1200	1480	2320	3710
AKH-0880	6"	DX	1500	3120	4910	8500	10300	12550	14800	19300	23700	37120	59460
		BX	360	750	1180	2050	2480	3020	3560	4640	5710	8940	14330
		CI	188	392	616	1064	1280	1560	1840	2390	2950	4620	7400
AKH-1480	8"	DX	2620	5450	8580	14860	18000	21900	25800	33700	41540	65050	104200
		BX	630	1310	2070	3580	4340	5300	6230	8120	10010	15680	25100
		CI	329	686	1078	1860	2250	2740	3230	4210	5190	8130	13020
AKH-2280	10"	DX	4080	8470	13350	23110	28000	34100	40200	52400	64590	101150	162050
		BX	1000	2070	3270	5660	6850	8340	9840	12800	15780	24700	39600
		CI	516	1077	1690	2920	3540	4310	5070	6610	8150	12760	20450

Compressed Air Filters

Flow Rates (metric)

Compressed Air Filters

Filter Housing Model	Port Size	Filter Cartridge Grade	Flow rates Nm ³ /hr, at 2 psi drop at indicated line pressure. Refer to Principal Specification for maximum pressure rating of each housing barg										
			0.14	1.4	2.8	5.5	6.9	8.6	10.3	13.8	17.3	27.6	44.8
A94A A914, A914D, A914P	1/4"	DX	7	15	22	241	49	61	73	93	114	—	
		BX	2	4	7	12	14	15	20	25	29	—	
2002	1/4"	DX	15	32	66	87	107	129	153	199	246	—	
2003	3/8"	BX	5	14	19	36	42	53	61	80	99	—	
2004	1/2"	CI	3	8	12	20	25	31	37	48	59	—	
2104	1/2"	DX	32	70	110	192	233	282	333	437	537	—	
		BX	15	32	51	87	107	129	153	199	246	—	
		CI	10	20	32	54	66	82	95	124	153	—	
2206	3/4"	DX	63	133	209	364	440	535	630	822	1013	—	
		BX	17	36	59	95	119	144	172	223	275	—	
		CI	14	27	44	75	90	110	129	168	207	—	
2208	1"	DX	93	195	308	533	646	787	928	1208	1490	—	
		BX	19	39	63	109	131	160	189	245	302	—	
		CI	17	34	54	95	114	139	163	212	262	—	
2312	1 1/2"	DX	167	345	542	941	1139	1386	1636	2131	2627	—	
		BX	37	78	126	219	263	321	379	493	608	—	
		CI	27	56	88	155	187	228	268	350	430	—	
A15/80	2"	DX	272	566	892	1543	1869	2277	2684	3500	4315	—	
		BX	76	160	251	435	527	642	756	985	1215	—	
		CI	39	83	131	226	274	335	392	511	630	—	
AKH-0280	3"	DX	618	1291	2022	3500	4248	5173	6116	7951	9803	15342	24602
		BX	153	323	510	866	1053	1283	1512	1971	2430	3806	6099
		CI	80	167	262	452	547	669	785	1023	1216	1971	3160
AKH-0480	4"	DX	1257	2616	4129	7153	8665	10551	12403	16225	19963	31262	50087
		BX	306	646	1002	1733	2107	2565	3024	3942	4859	7612	12199
		CI	160	333	523	1074	1094	1325	1563	2039	2515	3942	6303
AKH-0880	6"	DX	2549	5301	8342	14442	17500	21322	25145	32791	40266	63067	101023
		BX	612	1274	2005	3483	4214	5131	6048	7883	9701	15189	24347
		CI	319	666	1047	1808	2175	2650	3126	4061	5012	7849	12573
AKH-1480	8"	DX	4451	9260	14577	25247	30582	37208	43834	57256	70576	110520	177036
		BX	1070	2226	3517	6082	7374	9005	10585	13796	17007	26640	42645
		CI	559	1166	1832	3160	3823	4655	5488	7153	8818	13813	22121
AKH-2280	10"	DX	6932	14391	22682	39264	47572	57936	68300	89028	109738	171854	275323
		BX	1699	3517	5556	9616	11638	14170	16718	21747	26810	41965	67280
		CI	877	1830	2871	4961	6014	7323	8614	11230	13487	21679	34745

Compressed Air Filters

Filter Installation Recommendations

Removing Oil from Compressed Air

The source of oil in compressed air is the compressor lubricant. The common plant problems resulting from oil in the air are caused by liquid oil depositing in valves, instrument control surfaces, and other critical points in the air distribution system.

Balston often receives inquiries from users of compressed air about removing oil vapor from the air, yet the only reason for concern about oil vapor in most applications is that it may condense to liquid oil. Just like water vapor, oil vapor will condense to liquid when the temperature is reduced or the air pressure is increased at constant temperature. However, the table below shows that while in theory, condensation of oil vapor and water vapor are similar, in practice the effect of condensation of the two vapors is quite different.

Concentration of vapor, parts per million by weight (ppm) in air at 100 psig (7 barg), at indicated temperature

	Petroleum Base Oil	Synthetic Oil	Water
80°F (27°C)	0.012	0.002	2,743.
100°F (38°C)	0.05	0.01	5,137.
125°F (52°C)	0.2	0.06	10,508.
150°F (66°C)	0.7	0.2	20,119.
200°F (93°C)	3.5	2.4	62,371.

From the above figures, one can calculate that if 100 SCFM (170Nm³/h) of air is filtered at 125°F (52°C) to remove all liquids, and is subsequently cooled to 80°F (27°C), condensed liquids would consist of: water 3.6 lbs. (1.64 kg) per hour, and either petroleum base oil 0.001 lbs. (0.46 g) per hour, or synthetic oil 0.0003 lbs. (1.4 g) per hour. Condensed water is potentially a serious problem, but the quantity of condensed oil vapor is extremely small.

Field tests show that the liquid oil in air from a well-maintained reciprocating compressor is typically in the range of 15 to 30 ppm. With an oil-sealed rotary screw compressor, liquid oil content in the compressed air can vary from 10 to more than 100 ppm, depending upon the efficiency of the bulk oil separator. Compared to these figures, the approximate 0.2 ppm of liquid oil which could result from oil vapor condensation is for practical purposes negligible.

Therefore, removing the liquid oil from compressed air with a Balston coalescing filter, even at temperatures as high as 125°F (52°C), will eliminate the chance of oil-caused problems downstream in virtually all installations.

There are rare instances in which even 0.2 ppm oil vapor in the air or gas can cause a problem; for example, in contact with a sensitive catalyst or other highly reactive material.

In those cases, the trace quantity of oil vapor can be reduced using an adsorbent-loaded cartridge, following coalescing filter to remove the liquid oil.

Placing the Filter at the Point-Of-Use

Whether or not the system has an aftercooler, Balston strongly recommends a filter at each critical end-use point, even if a main line Grade DX filter has been used. The point-of-use filters will remove dirt and oil which may have been in the distribution lines, as well as water that has condensed downstream from the main filter. If there is a pressure regulator at the end-use point, the filter should be installed immediately upstream from the regulator. Alternatively, replace the existing regulator with a combination Balston filter-regulator.

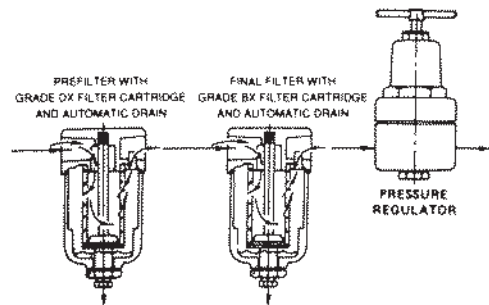

Point-of-Use Filter Recommendations

Microfibre Filter Cartridge	Grade BX
Filter Housing	Size from flow chart or by line size
Automatic Drain	Recommended (refer to Page 18)

If there is no Grade DX filter upstream from the final filter, or if a significant amount of water or oil is expected, then a two-stage system, Grade DX followed by Grade BX, is required at each use point. The housing and automatic drain for the Grade DX prefilter should be the same as for the Grade BX final filter (if the flow capacities permit).

Even if the application is not particularly sensitive to impurities in the air - for example, an air-driven tool - it is still good practice to remove condensed water with a filter at the end of the line. Parker recommends a single-stage Grade DX filter with automatic drain.

Compressed Air Filters

Filter Installation Recommendations

Using Filters With Air Dryers

Properly specified filters are relatively inexpensive protection for air dryers. Both refrigerated and desiccant dryers benefit from filter protection.

Refrigerated Dryers

A Grade DX prefilter with automatic drain should be installed upstream from a refrigerated dryer to prevent oil and condensed water from entering the dryer. Oil entering a dryer coats the cooling coil and reduces its efficiency; condensed water increases the cooling load and reduces dryer capacity. A dryer that was in operation before a Balston filter was installed may already have oil inside it. Therefore a second filter, a Grade BX filter with automatic drain, must be installed downstream from the dryer if oil-free air is required.

Desiccant Dryers

Desiccant dryers are very sensitive to water and oil droplets. Water can saturate the desiccant and reduce its drying efficiency or even destroy it. Oil can coat the desiccant, rendering it ineffective, or the oil can accumulate on the desiccant and create a combustion hazard when the desiccant is heated for regeneration.

For maximum protection of the desiccant dryer, a two-stage filter (Grade DX followed by Grade BX) system with automatic drains should be installed upstream from the dryer. To protect downstream delivery points from abrasive desiccant particles, a high efficiency filter with high solids holding capacity should be installed downstream from the dryer. The Balston Grade DX filter cartridge is recommended for this downstream installation location. (Note: All Balston desiccant dryers are equipped with prefilters and final filters, as recommended above).

Membrane Dryers

Membrane air dryers are sensitive to water and oil droplets. Oil can permanently damage the hollow fiber core. Balston Membrane Air Dryers are assembled with maximum protection, two stage coalescing filters (Grade DX followed by BX) designed to remove all contaminants down to 0.01 microns. Most all other membrane dryers are not assembled with adequate prefiltration protection and should be protected with a two stage Balston Filter System (Grade DX, Grade BX).

Maintaining The Filters

In a typical compressed air delivery system, a properly specified Balston filter cartridge can be expected to last for one year. The filter cartridge can continue to coalesce indefinitely, but solids loading in the depth of the cartridge will cause a pressure drop through the housing. The filter should be changed when the pressure drop reaches 10 psi (0.7 barg). At pressure drops higher than 10 psig (0.7 barg), the cartridge will continue to perform at its rated efficiency, but downstream instrumentation may be affected by the pressure drop.

To monitor the condition of the filters, install Balston Differential Pressure Indicators (DPI) on the filters or across a multi-filter installation. The DPI gives a visual indication of differential pressure through the filter cartridge. The Balston Differential Pressure Indicator is factory-installed on 1/4" and larger line size Balston Compressed Air Filter Assemblies. To use a DPI with a smaller Balston Compressed Air Filter, pressure taps must be provided with "tees" on the line upstream and downstream from the filter.

Compressed Air Filters

1/4" and 1/2" Line Size Filters

Models A914D, A914P, A914, A914A

Models A914P and A914D are 1/4" line size assemblies with simple, reliable "automatic" drains used for low flow applications with moderate levels of liquid contaminate. The A914P is designed to empty condensate when there is a sudden pressure drop through the system (intermittent compressed air demand applications). The A914D incorporates an overnight drain which will drain liquid contaminate when the compressed air system pressure drops below 5 psig (0.4 barg). The standard A914 utilizes a standard manual threaded drain. All models have a transparent polycarbonate bowl with an aluminum head. The Model A914A has a zinc bowl.



Model A914D,
A914P, A914



Model A914A

Models 2002, 2003, and 2004

Models 2002 and 2003 are 1/4" and 3/8" line size assemblies. These filters have increased liquid holding capacity and are equipped with high capacity float drains, differential pressure indicators, sightglass, pressure relief valve, and 1/4 turn bayonet bowl closures. The 2004 series is designed to service 1/2" compressed air lines with low flow rates.

Model 2104

The Model 2104 is a 1/2" line size assembly with an aluminum bowl. The filter housing has a large liquid holding capacity and a high capacity float drain, differential pressure indicator, sightglass, pressure relief valve, and 1/4 turn bayonet bowl closure.



Model 200X Series



Model 2104 Series

Compressed Air Filters

1/4" and 1/2" Line Size Filters

Principal Specifications

Model	A914	A914A	2002, 2003, 2004 (1)	2104 (1)
Port Size	1/4" NPT	1/4" NPT	1/4", 3/8", 1/2" NPT	1/2" NPT
Materials of Construction				
Head	Anod. Alum.	Anod. Alum.	Anod. Alum.	Anod. Alum.
Bowl	Polycarbonate	Zinc	Anod. Alum.	Anod. Alum.
Internals	Nylon	Nylon	Nylon	Nylon
Seals	Buna-N	Buna-N	Buna-N	Buna-N
Maximum Temperature	120°F (49°C)	220°F (104°C)	130°F (54°C) (2)	130°F (54°C) (2)
Maximum Pressure	150 psig (10.3 barg) (3)	250 psig (17.2 barg) (3)	250 psig (17.2 barg) (3)	250 psig (17.2 barg) (3)
Minimum Pressure	5 psig (0.4 barg) (4)	5 psig (0.4 barg) (4)	15 psig (1.03 barg) (4)	15 psig (1.03 barg) (4)
Shipping Weight	0.5 lbs. (0.2 kg)	0.5 lbs. (0.2 kg)	2.0 lbs. (0.9 kg)	2.5 lbs. (1.1 kg)
Dimensions	1.5"W X 4.0"L (4cm X 10cm)	1.5"W x 4.0"L (4cm X 10cm)	3.3"W X 8.5"L (8cm X 20cm)	3.3"W X 11.3"L (8cm X 28cm)

Ordering Information

For assistance, call toll-free at 1-800-343-4048 8AM to 5PM Eastern Time

Model	A914	A914A (8)	2002, 2003, 2004 (1)	2104 (1)
Differential Pressure Indicator	Not Included (7)	Not Included (7)	Included (7)	Included (7)
Replacement Filter Cartridges				
No. Required	1	1	1	1
Box of 5	5/050-05-□ (5)	5/050-05-□ (5)	5/100-12-□ (5)	5/100-18-□ (5)
Cartridges Box of 10	050-05-□ (5)	050-05-□ (5)	100-12-□ (5)	100-18-□ (5)
CI Cartridge Box of 1	—	—	CI-100-12-000 (5)	CI-100-25-000 (5)

Notes:

- 1 Lifetime (20 year) Warranty included. Contact your local representative for details.
- 2 Automatic drain and Differential Pressure Indicator are temperature limiting factors. For Temperature capabilities to 220°F (104°C), order assemblies without automatic Drain and Differential Pressure Indicator.
- 3 Maximum pressure ratings are for temperatures to 130°F (54°C). Please consult factory for maximum pressure ratings at elevated temperatures.
- 4 Required for proper operation of piston drain, overnight drain, or float drain.
- 5 Indicate grade of filter cartridge by putting appropriate letter after ordering number. To order assembly with Type CI cartridges, add-000 after assembly number. Example: 2104N-0A0-000
- 6 Automatic drains not supplied with assemblies containing Type CI cartridges.
- 7 Differential Pressure Indicator (DPI) Kit may be ordered separately, P/N 41-071. DPI is sensitive in the range of 0-7 psi differential.
- 8 Order A914D- _X for overnight drain installed in the filter assembly.
Order A914P- _X for piston drain installed in the filter assembly.
Order A914A- _X for aluminum bowl and 250 psig rating.

How to Order the Filter Assembly*

Build your own custom filter assembly using the guideline matrix below and specify your model number. Example: 1/2" filter with DPI and Auto Drain with Grade DX Filter = 2104N-1B1-DX.

*Consult Factory. Not all configurations are available.

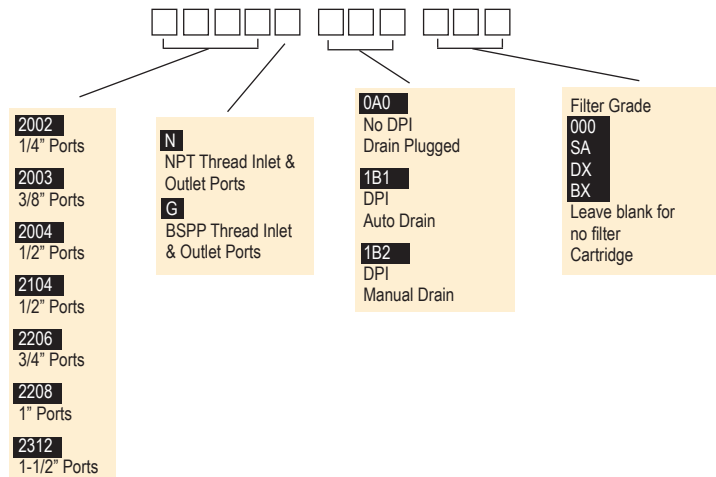

Compressed Air Filters

3/4" to 2" Line Size Filters

Models 2206, 2208, 2312, and A15/80

The Model A15/80 filter assembly has 2" NPT inlet and outlet ports, an automatic float drain and differential pressure indicator installed. The Models 2206, 2208, and 2312 filter assemblies have 3/4", 1", and 1 1/2" NPT inlet and outlet ports, respectively; these models are also equipped with automatic drains, sight glasses, pressure relief valve, bayonet closures, and differential pressure indicators. Materials of construction are shown below.



Model 2312N



Model 2206N



Model A15/80

Compressed
Air Filters

Principal Specifications

Model	2206 (1)	2208 (1)	2312 (1)	A15/80
Port Size	3/4" NPT	1" NPT	1 1/2" NPT	2" NPT
Materials of Construction				
Head	Anod. Alum.	Anod. Alum.	Anod. Alum.	Anod. Alum.
Bowl	Anod. Alum.	Anod. Alum.	Anod. Alum.	Steel
Internals	Aluminum	Aluminum	Aluminum	St. Steel
Seals	Buna-N	Buna-N	Buna-N	Buna-N
Maximum Temperature	130°F (54°C) (2)	130°F (54°C) (2)	130°F (54°C) (2)	130°F (54°C) (2)
Maximum Pressure	250 psig (17.2 barg) (3)	250 psig (17.2 barg) (3)	250 psig (17.2 barg) (3)	250 psig (17.2 barg) (3)
Minimum Pressure	15 psig (1 barg) (4)	15 psig (1 barg) (4)	15 psig (1 barg) (4)	15 psig (1 barg) (4)
Shipping Weight	8 lbs. (3.6 kg)	8 lbs. (3.6 kg)	15 lbs. (6.8 kg)	11 lbs. (5 kg)
Dimensions	4"W X 13"L (10cm X 33cm)	4"W X 13"L (10cm X 33cm)	5.0"W X 17"L (13cm X 43cm)	6.3"W X 28"L (16cm X 71cm)

Notes:

1 Lifetime (20 year) Warranty included. Contact your local representative for details.

2 Automatic Drain and Differential Pressure Indicator are limiting factors. For temperature capabilities to 220°F (104°C), order assemblies without Auto Drain and Differential Pressure Indicator.

3 Maximum pressure ratings are for temperatures to 130°F (54°C). Please consult factory for maximum pressure ratings at elevated temperatures.

4 Required for proper operation of the float drain.

5 Indicate grade of filter cartridge by putting appropriate letter after ordering number (please refer to PK1-2). Example: 5/150-19-DX, 200-35-BX.

6 The DPI is sensitive in the range of 0-5 psi differential.

Ordering Information

For assistance, call toll-free at 1-800-343-4048 8AM to 5PM Eastern Time

Model	2206	2208	2312	A15/80
Differential Pressure Indicator	Included (6)	Included (6)	Included (6)	Included (6)
Replacement Filter Cartridges				
No. Required	1	1	1	1
Box of 5	5/150-19-□ (5)	5/150-19-□ (5)	5/200-35-□ (5)	5/200-80-□ (5)
Box of 10	150-19-□ (5)	150-19-□ (5)	200-35-□ (5)	200-80-□ (5)
CI Cartridge (Box of 1)	CI150-19-000	CI150-19-000	CI200-35-000	CI200-80-000



Compressed Air Filters

Compressed Air Filters

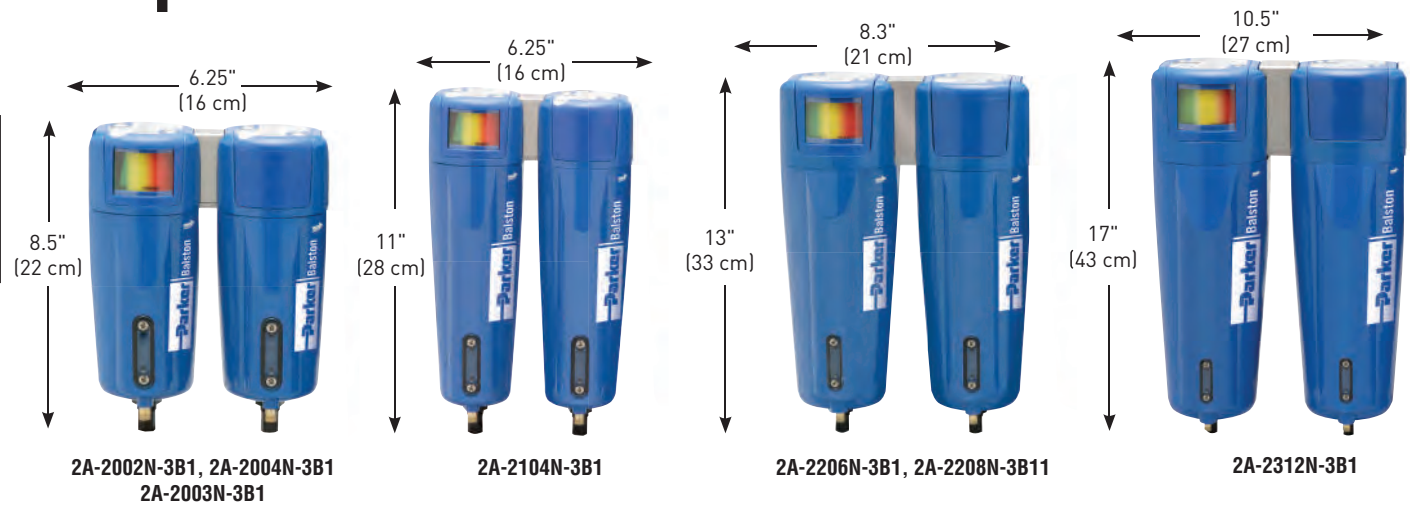

Principal Specifications

Model	2A-2002, 2003, 2004	2A-2104	2A-2206	2A-2208	2A-2312
Port Size	1/4" NPT	1/2" NPT	3/4" NPT	1" NPT	1.5" NPT
Materials of Construction					
Head	Aluminum	Aluminum	Aluminum	Aluminum	Aluminum
Bowl	Aluminum	Aluminum	Aluminum	Aluminum	Aluminum
Internals	Aluminum	Aluminum	Aluminum	Aluminum	Aluminum
Seals	Buna-N Food Grade	Buna-N Food Grade	Buna-N Food Grade	Buna-N Food Grade	Buna-N Food Grade
Maximum Temperature (1)	130°F (54°C)	130°F (54°C)	130°F (54°C)	130°F (54°C)	130°F (54°C)
Maximum Pressure	250 psig (17.2 barg)	250 psig (17.2 barg)	250 psig (17.2 barg)	250 psig (17.2 barg)	250 psig (17.2 barg)
Minimum Pressure (2)	15 psig (1 barg)	15 psig (1 barg)	15 psig (1 barg)	15 psig (1 barg)	15 psig (1 barg)
Shipping Weight	4.2 lbs. (1.9 kg)	5 lbs. (2.3 kg)	11.7 lbs. (5.3 kg)	11.7 lbs. (5.3 kg)	27 lbs. (12 kg)
Dimensions	6.25"W X 8.5"L	6.25"W X 11"L	8.3"W X 13"L	8.3"W X 13"L	10.5"W X 17"L

Notes:

- 1 Max. temperature with auto drain 2 Required for proper operation of auto drain.

Ordering Information For assistance, call toll-free at 1-800-343-4048 8AM to 5PM Eastern Time

Assembly Ordering Information

Model P/N		Replacement Cartridge	
		Box of 5	Box of 10
2A-2002N-3B1	1/4" 2-Stage (DX, BX) Filter Assembly	5/100-12-DX	100-12-DX
2A-2003N-3B1	3/8" 2-Stage (DX, BX) Filter Assembly	5/100-12-BX	100-12-BX
2A-2004N-3B1	1/2" 2-Stage (DX, BX) Filter Assembly		
2A-2104N-3B1	1/2" 2-Stage (DX, BX) Filter Assembly	5/100-18-DX 5/100-18-BX	100-18-DX 100-18-BX
2A-2206N-3B1	3/4" 2-Stage (DX, BX) Filter Assembly	5/150-19-DX 5/150-19-BX 5/150-19-SA	150-19-DX 150-19-BX
2A-2208N-3B1	1" 2-Stage (DX, BX) Stainless Assembly	5/150-19-DX 5/150-19-BX 5/150-19-SA	150-19-DX 150-19-BX
2A-2312N-3B1	1" 2-Stage (DX, BX) Stainless Assembly	5/200-35-DX 5/200-35-BX	200-35-DX 200-35-BX

- 4 2 each of mounting brackets are required for adequate support.
5 For CRN rated assemblies add a "C" to the Model Number. Example: 2A-C2104N-3B1

Compressed Air Filters

3" to 10" Line Size Filters

New LF/FF Series Multiple Cartridge Filter Assemblies

These filter assemblies provide high efficiency filtration of compressed air and other compressed gases at very high flow rates. With inlet and outlet ports accommodating 3" to 10" pipe sizes, the new LF/FF Series housings are capable of flow rates up to a maximum capacity of 37,350 SCFM (63,458 m³/h) at 100 psig (6.9 barg). The standard carbon steel units, which are generally in stock (through 6" line sizes), have pressure ratings up to 250 psig (17.2 barg).

All LF/FF series housings are ASME Code Stamped for the rated maximum operating pressure. All FF Series vessels have built-in legs for floor mounting. Selected models have swing bolt enclosures for easy access to the internals. The filter cartridges in all models are sealed by tightening the threaded retainer cap onto the rigid tie rod, ensuring a leak tight seal on both ends of the cartridge.

Each assembly is equipped with a carbon steel automatic float drain, differential pressure indicator, and a set of filter cartridges (except where noted).



Compressed Air Filters

Benefits

<i>Low Pressure Drop</i>	<i>Heat and Chemical Resistant</i>
<i>Lower Change out/Labor Costs</i>	<i>No Wet Zone</i>
<i>Lower Energy Costs</i>	<i>Oleophobic/Hydrophobic</i>
<i>High Dirt Holding Capacity</i>	<i>High Burst Strength</i>

Calculation with Part-Load Operation (100 hp compressor)

Annual Electricity Costs =
 [(Motor full-load brake horsepower) x (0.746 kW/hp)
 x (Annual Hours of Operation) x (Electricity Cost in \$/kWh)] x [(Percent of
 time running fully loaded) + (0.30) x (Percent of time running unloaded)]
 For example:
 Full load motor efficiency = 90%
 Motor full load bhp = 100 hp
 Annual hours of operation = 8,760 hours (3-shift, continuous operation)
 Runs 65% of the time fully loaded, 35% of the time unloaded
 Unloaded operation consumes 30 percent of the electricity of fully loaded
 operation
 Cost of electricity = \$0.10/kWh
Annual electricity costs =
 [(100 hp) x (0.746 hp/kW) x (8,760 hrs) x \$0.10/kWh / 0.9] x [0.65 + (0.30) x
 (0.35)] = **\$54,272.00**

Compressed Air Filters

3" to 10" Line Size Filters

HFC Savings

Annual electricity costs to operate a 100 HP Compressor can be as high as \$50,000. Pressure loss in the system adds to this expense. For a system operating at 100 psig (7 barg) that loses 2 psig (0.14 barg) of pressure through a filter, requires an additional 1% in operating energy costs (1).

Installing a single stage HFC Filter in place of a standard brand X filter, will reduce the pressure drop by 2+ psi (0.14 barg).

Based on a standard 100 HP (74.6 kW) compressor operating at a 65% load cycle, a 1% reduction in annual operating costs would be equal to \$542.00

NEW!

High Flow Coalescing Filter Media HFC Grade

Efficiency: 99.5% @ 0.5 micron

Balston's HFC media consists of two layers. The outer layer features a dense matrix of glass fibers. It provides highly efficient coalescing aerosol removal and very low pressure drop. The inner layer, or initial stage of filtration, effectively traps dirt particles, protecting and extending the life of the outer layer. A metal retainer is used for strength and stability. This media is used in bulk coalescing applications and when relatively high efficiency and low pressure drop are required.



High Efficiency Coalescing Media HEC Grade

Efficiency: 99.97% @ 0.01 micron

Air Flow: Inside to Outside

This coalescing element is composed of an epoxy saturated borosilicate glass micro-fiber tube. The HEC grade filter has a pleated cellulose inner layer as a built-in prefilter. This element is metal retained for added strength, and includes a synthetic fabric layer.

HEC filters are used when "total removal of liquid aerosols and suspended fines" is required. Because of its overall performance characteristics, this grade is most often recommended.

The HEC element is great prefilter protection for desiccant air dryers. This element prevents oil or varnish from coating the desiccant, while maintaining the dryer efficiency.

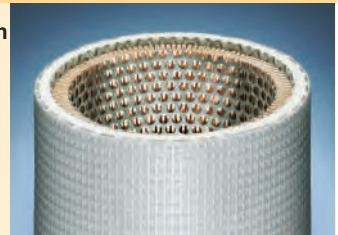

(1) Compressed Air Challenge, Doc # F9-1, April, 1998-Rev.0.

Compressed Air Filters

HFC MEDIA Max. Rated Flows (SCFM) at Various Operating Pressures (0.25 psi pressure drop)

Model Number	2 psig	20 psig	40 psig	80 psig	100 psig	125psig	150 psig	175 psig	200 psig	220 psig	250 psig
ALN3-0128-HFC	363	753	1187	2056	2490	3033	3575	4118	4661	5095	5746
ALF3-0128-HFC	363	753	1187	2056	2490	3033	3575	4118	4661	5095	5746
ALF4-0125-HFC	483	1004	1583	2741	3320	4044	4767	5491	6215	6793	N/A
ALF6-0136-HFC	725	1507	2375	4112	4980	6065	7151	8236	9322	10190	N/A
ALF6-0328-HFC	1088	2260	3562	6167	7470	9098	10726	12354	13983	15285	N/A
AFN3-0128-HFC	363	753	1187	2056	2490	3033	3575	4118	4661	5095	5746
AFF3-0128-HFC	363	753	1187	2056	2490	3033	3575	4118	4661	5095	5746
AFF4-0125-HFC	483	1004	1583	2741	3320	4044	4767	5491	6215	6793	N/A
AFF6-0136-HFC	725	1507	2375	4112	4980	6065	7151	8236	9322	10190	11493
AFF6-0328-HFC	1088	2260	3562	6167	7470	9098	10726	12354	13983	15285	N/A
AFF8-0428-HFC	1450	3013	4750	8223	9960	12131	14302	16472	18644	20380	22984
AFF10-0728-HFC	2538	5273	8312	14391	17430	21229	25028	28826	32627	35665	40222
AFF12-1128-HFC	3988	8286	13062	22614	27390	33360	39330	45298	51271	56045	63206
AFF16-1528-HFC	5438	11299	17812	30837	37350	45491	53632	61770	69915	76425	86190

HEC MEDIA Max. Rated Flows (SCFM) at Various Operating Pressures (1.5 psi pressure drop)

Model Number	2 psig	20 psig	40 psig	80 psig	100 psig	125 psig	150 psig	175 psig	200 psig	220 psig	250 psig
ALN3-0128-HEC	218	454	715	1238	1500	1827	2154	2481	2808	3069	3462
ALF3-0128-HEC	218	454	715	1238	1500	1827	2154	2481	2808	3069	3462
ALF4-0125-HEC	219	605	954	1651	2000	2436	2872	3308	3744	4092	N/A
ALF6-0136-HEC	437	908	1431	2477	3000	3654	4308	4962	5616	6139	N/A
ALF6-0328-HEC	654	1362	2145	3714	4500	5481	6462	7443	8424	9207	N/A
AFN3-0128-HEC	218	454	715	1238	1500	1827	2154	2481	2808	3069	3462
AFF3-0128-HEC	218	454	715	1238	1500	1827	2154	2481	2808	3069	3462
AFF4-0125-HEC	291	605	954	1651	2000	2436	2872	3308	3744	4092	N/A
AFF6-0136-HEC	437	908	1431	2477	3000	3654	4308	4962	5616	6139	6923
AFF6-0328-HEC	654	1362	2145	3714	4500	5481	6462	7443	8424	9207	N/A
AFF8-0428-HEC	872	1816	2860	4952	6000	7308	8616	9924	11232	12276	13848
AFF10-0728-HEC	1526	3178	5005	8666	10500	12789	15078	17367	19656	21483	24234
AFF12-1128-HEC	2398	4994	7865	13618	16500	20097	23694	27291	30888	33759	38082
AFF16-1528-HEC	3270	6810	10725	18570	22500	27405	32310	37215	42120	46035	51930

Compressed Air Filters

HFC MEDIA Max. Rated Flows (Nm³/hr) at Various Operating Pressures (0.017 barg pressure drop)

Model Number	0.2 barg	1.4 barg	3 barg	4 barg	7barg	9 barg	10 barg	12 barg	14 barg	17 barg	20 barg
ALN3-0128-HFC	649	1291	2147	2681	4286	5355	5890	6960	8029	9634	11238
ALF3-0128-HFC	649	1291	2147	2681	4286	5355	5890	6960	8029	9634	11238
ALF4-0125-HFC	865	1721	2862	3575	5714	7141	7854	9280	10706	12846	N/A
ALF6-0136-HFC	1299	2582	4293	5363	8572	10711	11781	13920	16059	19268	N/A
ALF6-0336-HFC	1947	3873	6440	8044	12857	16066	17671	20879	24088	28901	N/A
AFN3-0128-HFC	649	1291	2147	2681	4286	5355	5890	6980	8029	9634	11238
AFF3-0128-HFC	649	1291	2147	2681	4286	5355	5890	6980	8029	9634	11238
AFF4-0125-HFC	865	1721	2862	3575	5714	7141	7854	9280	10706	12846	N/A
AFF6-0136-HFC	1233	2532	4265	5348	8597	10763	11846	14012	16178	19427	22676
AFF6-0328-HFC	1947	3873	6440	8044	12857	16066	17671	20879	24088	28901	N/A
AFF8-0428-HFC	2597	5164	8587	10726	17143	21422	23561	27839	32118	38535	44953
AFF10-0728-HFC	4519	9013	15005	18750	29984	37474	41219	48709	56199	67433	78668
AFF12-1128-HFC	7141	14200	23613	29496	47144	58909	64792	76557	88323	105971	123619
AFF16-1528-HFC	9738	19364	32199	40221	64287	80331	88353	104396	120440	144506	168572

HEC MEDIA Max. Rated Flows (Nm³/hr) at Various Operating Pressures (0.10 barg pressure drop)

Model Number	0.2 barg	1.4 barg	3 barg	4 barg	7barg	9 barg	10 barg	12 barg	14 barg	17 barg	20 barg
ALN3-0128-HEC	391	777	1293	1615	2582	3227	3549	4194	4839	5805	6772
ALF3-0128-HEC	391	777	1293	1615	2582	3227	3549	4194	4839	5805	6772
ALF4-0125-HEC	481	1001	1695	2128	3429	4295	4729	5596	6463	7763	N/A
ALF6-0136-HEC	782	1556	2587	3232	5165	6454	7099	8388	9677	11611	N/A
ALF6-0328-HEC	1172	2332	3879	4846	7747	9681	10648	12581	14515	17416	N/A
AFN3-0128-HEC	391	777	1293	1615	2582	3227	3549	4194	4839	5805	6772
AFF3-0128-HEC	391	777	1293	1615	2582	3227	3549	4194	4839	5805	6772
AFF4-0125-HEC	481	1001	1695	2128	3429	4295	4729	5596	6463	7763	N/A
AFF6-0136-HEC	782	1556	2587	3232	5165	6454	7099	8388	9677	11611	13544
AFF6-0328-HEC	1172	2332	3879	4846	7747	9681	10648	12581	14515	17416	N/A
AFF8-0428-HEC	1563	3110	5172	6462	10329	12908	14197	16775	19354	23221	27089
AFF10-0728-HEC	2735	5442	9052	11308	18076	22588	24844	29357	33869	40637	47405
AFF12-1128-HEC	4297	8552	14224	17770	28406	35497	39042	46133	53224	63860	74496
AFF16-1528-HEC	3449	6864	11416	14262	22798	28489	31335	37026	42717	51253	59790

Housing Selection Chart

Model Number	HFC Replacement Element	HEC Replacement Element	Port Size	Port Type	# of Elements
LINE MOUNT VESSELS					
ALN3-0128-H?C	510-28- HFC	510-28-HEC	3	NPT	1
ALF3-0128-H?C	510-28- HFC	510-28- HEC	3	FLANGE	1
ALF4-0125-H?C	850-25- HFC	850-25- HEC	4	FLANGE	1
ALF6-0136-H?C	850-36- HFC	850-36- HEC	6	FLANGE	1
ALF6-0328-H?C	510-28- HFC	510-28- HEC	6	FLANGE	3
FLOOR MOUNT VESSELS					
AFN3-0128-H?C	510-28- HFC	510-28- HEC	3	NPT	1
AFF3-0128-H?C	510-28- HFC	510-28- HEC	3	FLANGE	1
AFF4-0125-H?C	850-25- HFC	850-25- HEC	4	FLANGE	1
AFF6-0136-H?C	850-36- HFC	850-36- HEC	6	FLANGE	1
AFF6-0328-H?C	510-28- HFC	510-28- HEC	6	FLANGE	3
AFF8-0428-H?C	510-28- HFC	510-28- HEC	8	FLANGE	4
AFF10-0728-H?C	510-28- HFC	510-28- HEC	10	FLANGE	7
AFF12-1128-H?C	510-28- HFC	510-28- HEC	12	FLANGE	11
AFF16-1528-H?C	510-28- HFC	510-28- HEC	16	FLANGE	15

Compressed Air Filters

Drawings, Dimensions & Specifications

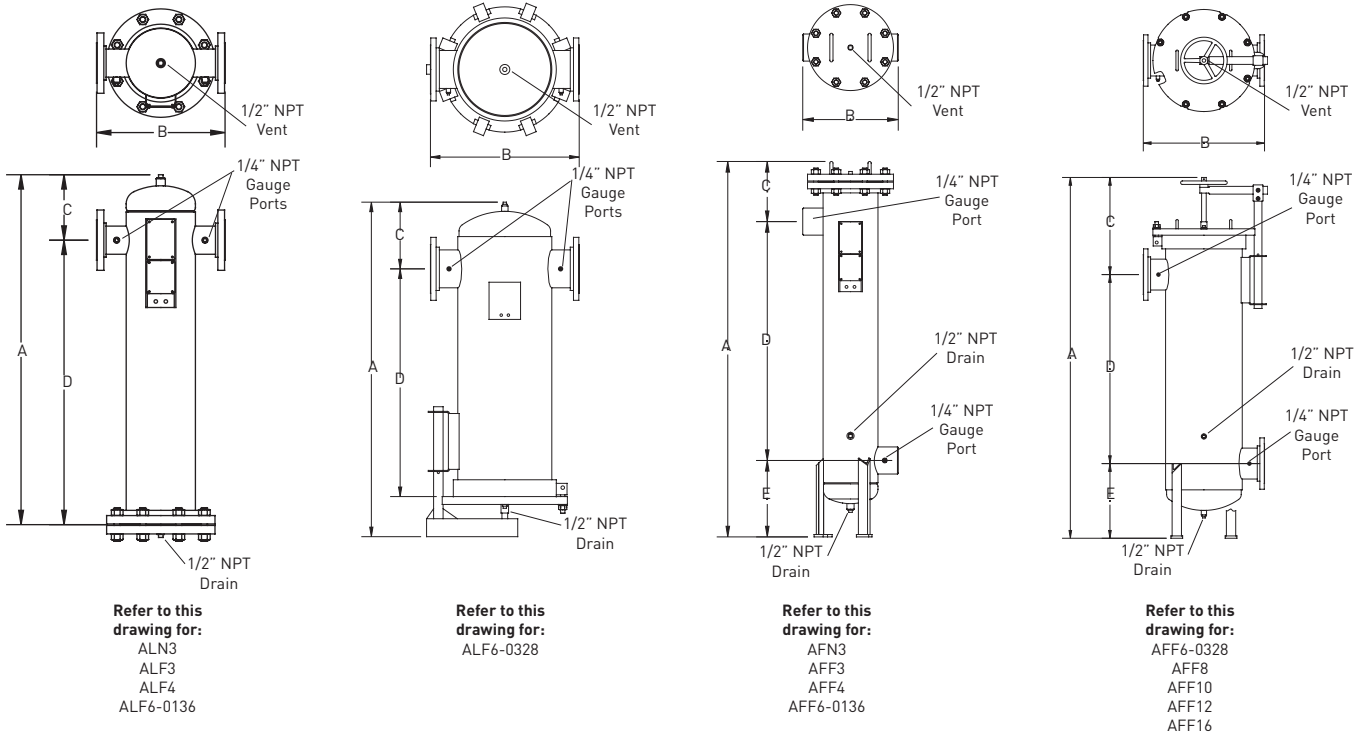

Dimensions	A	B	C	D	E	Element Removal Clearance Inches (centimeters)	Sump Capacity gallons (liters)	Weight pounds (kilograms)
ALN3	43.1 (109.5)	15.0 (38.1)	7.7 (19.5)	35.4 (89.9)	—	28 (71.1)	0.81 (3)	190 (86)
ALF3	43.1 (109.5)	16.0 (40.6)	7.7 (19.5)	35.4 (89.9)	—	28 (71.1)	0.81 (3)	190 (86)
ALF4	42.7 (108.5)	20.0 (50.8)	9.7 (24.6)	33.0 (83.8)	—	25 (63.5)	2.0 (7)	380 (173)
ALF6-0136	56.4 (143.3)	20.0 (50.8)	11.4 (29.0)	45.0 (114.3)	—	36 (91.4)	2.0 (7)	380 (173)
ALF6-0328	57.8 (146.8)	26.0 (66.0)	11.0 (27.9)	39.8 (101.1)	—	28 (71.1)	2.0 (7)	340 (155)
AFN3	58.9 (149.6)	15.0 (38.1)	9.4 (23.8)	37.5 (95.2)	12.0 (30.4)	28 (71.1)	1.1 (4)	190 (86)
AFF3	58.9 (149.6)	16.0 (40.6)	9.4 (23.8)	37.5 (95.2)	12.0 (30.4)	28 (71.1)	1.2 (4)	200 (91)
AFF4	63.3 (160.7)	20.0 (50.8)	12.3 (31.2)	35.0 (88.9)	16.0 (40.6)	25 (63.5)	4.2 (16)	370 (168)
AFF6-0136	75.3 (191.2)	20.0 (50.8)	12.3 (31.2)	47.0 (119.3)	16.0 (40.6)	36 (91.4)	3.6 (14)	410 (186)
AFF6-0328	77.3 (196.3)	26.0 (66.0)	20.8 (52.8)	40.5 (102.8)	16.0 (40.6)	28 (71.1)	5.0 (19)	340 (155)
AFF8	87.3 (221.7)	30.0 (76.2)	25.8 (65.5)	42.5 (108.0)	19.0 (48.3)	28 (71.1)	8.7 (33)	550 (250)
AFF10	96.0 (243.8)	34.0 (86.3)	28.5 (72.4)	45.5 (115.5)	22.0 (55.8)	28 (71.1)	14.8 (56)	750 (341)
AFF12	101.0 (256.5)	44.0 (111.7)	27.5 (69.8)	47.5 (120.6)	26.0 (66.0)	28 (71.1)	25.5 (97)	1300 (591)
AFF16	112.0 (284)	52.0 (132.0)	32.0 (81.3)	50.0 (127.0)	30.0 (76.2)	28 (71.1)	56.2 (213)	1700 (773)

Materials of Construction

Body: Carbon Steel
Paint: Epoxy Enamel (Gray)
Internals: Epoxy powder painted carbon steel
Seals: Inorganic flange gasket (single element vessels)
 Fluorocarbon o-ring (multi element vessels)
Internal Coating: Epoxy enamel

Specifications

Max Pressure: Up to 220-250 PSIG (15.2-17.2 barg)
 (Consult Flow Chart)
Max Temperature: 225°F (107°C)
Meets A.S.M.E. Code, Section VIII, Division 1:
Note: Consult factory for special requirements

Compressed Air Filters

Balston High Pressure Compressed Air Filters

Balston high pressure compressed air filters offer exceptionally high efficiency coalescing filtration of compressed air at high flow rates. The housings are ASME Code stamped to 665 psig.

Since the coalesced liquid drains continuously from the filter cartridges as rapidly as it is collected, the filters have an unlimited capacity for liquid removal.

Each filter cartridge is mounted on a rigid permanent filter holder with a vibration-resistant removable tube retainer. The filter cartridge is self gasketing, and the filter holder is designed so that a perfect seal is easily made, even when the tube is replaced by an operator unfamiliar with the equipment.

AKH housings are available with inlet and outlet ports covering the range from 3" to 10" pipe sizes.



Model (5)	AKH-0280	AKH-0480	AKH-0880	AKH-1480	AKH-2280
Port Size	3" FLG	4" FLG	6" FLG	8" FLG	10" FLG
Materials of Construction					
Vessel	Carbon Steel	Carbon Steel	Carbon Steel	Carbon Steel	Carbon Steel
Filter Cartridge Holders	303 St. Steel	303 St. Steel	303 St. Steel	303 St. Steel	303 St. Steel
Seals	Buna-N	Buna-N	Buna-N	Buna-N	Buna-N
Maximum Temperature	250°F (121°C) (1)	250°F (14°C) (1)	250°F (121°C) (1)	250°F (121°C) (1)	250°F (121°C) (1)
Maximum Pressure	665 psig (45.9 barg) (2)	665 psig (45.9 barg) (2)	665 psig (45.9 barg) (2)	665 psig (45.9 barg) (2)	665 psig (45.9 barg) (2)
Minimum Pressure	10 psig (0.69 barg)	10 psig (0.69 barg)	10 psig (0.69 barg)	10 psig (0.69 barg)	10 psig (0.69 barg)
Shipping Weight	150 lbs. (68 kg)	270 lbs. (123 kg)	560 lbs. (254 kg)	1120 lbs. (508 kg)	1430 lbs. (649 kg)
Dimensions	16"W X 41"H (41cm X 104cm)	21"W X 40"H (53cm X 102cm)	25"W X 43"H (64cm X 109cm)	34"W X 54"H (86cm X 137cm)	36"W X 57"H (91cm X 145cm)
Flange Center Line to Floor Dimension	7.75" (20cm)	6.25" (16cm)	8.5" (22cm)	16.25" (41cm)	17.25" (44cm)
Flange to Flange Dimension	15.63" (40cm)	20.63" (52cm)	24.75" (63cm)	34" (86cm)	36" (91cm)

For assistance, call toll-free at 1-800-343-4048 8AM to 5PM Eastern Time

Model (3)	AKH-0280-□	AKH-0480-□	AKH-0880-□	AKH-1480-□	AKH-2280-□
Replacement Filter Cartridges					
No. Required	2	4	8	14	22
Box of 5	5/200-80-□ (4)	5/200-80-□ (4)	5/200-80-□ (4)	5/200-80-□ (4)	5/200-80-□ (4)
Box of 10	200-80-□ (4)	200-80-□ (4)	200-80-□ (4)	200-80-□ (4)	200-80-□ (4)
CI Cartridge (Box of 1)	CI-200-80-000	CI-200-80-000	CI-200-80-000	CI-200-80-000	CI-200-80-000

Notes:

1 Maximum operating temperature of carbon steel vessel is 650°F (343°C). Minimum operating (process and ambient pressure) temperature is -20°F (29°C). Max. Temps.

for Seal material: 250°F (Buna), 400°F (Viton), 450°F (Silicone). Seal material may not be the limiting factor. Maximum temperature for assemblies with DPI is 130°F (54°C)

2 Vessel is ASME Section VIII, Div. 1 code stamped for rated pressure.

3 Differential Pressure Indicator and Automatic Drain are not included with AKH Assemblies, or with assemblies containing Type CI Cartridges.

4 To order filter cartridges, indicate grade of filter cartridge by placing appropriate letter cartridge designation after the last digit. Example: 200-80-DX.

Stainless Steel Compressed Air Filters for Harsh Environments

Balston Stainless Steel Compressed Air Filter Assemblies:

Balston Compressed Air Filters protect your equipment and delicate instruments from the dirt, water, and oil usually found in compressed air and other gases. These filters will remove contaminants at a very high efficiency - up to 99.99% for 0.01 micron particles and droplets. Liquid releases from the filter cartridge to an automatic drain as rapidly as it enters the filter. This allows the filter to continue removing liquids for an unlimited time without loss of efficiency or flow capacity. Select 1/4" to 1" line filters are constructed of 304 stainless steel and are designed to hold up to the harshest environments.



Product Features:

- All 304 stainless steel construction, ideal standing up to aggressive washdown chemicals
- Remove 99.99% of 0.01 micron particles of oil, water, and dirt from compressed air and other gases
- For Sterile Air Requirements:
- USDA accepted for use in federally inspected meat and poultry plants
- Low pressure drop
- Continuously trap and drain liquids
- Remove trace oil vapor with adsorbent cartridges

Petrochemical

Textiles

Pulp and Paper

Refineries



Compressed Air Filters

Stainless Steel Filters for Harsh Environments

Filter Cartridge Description

General purpose applications such as plant compressed air	Single stage filtration. Use a Grade DX filter cartridge
Instrument air and other critical air requirements	Two stage filtration is necessary. Use a Grade DX followed by a Grade BX filter cartridge. As a general rule, a Grade BX filter cartridge should not be used alone.
Removal of trace compressor oil vapor	For rare instances where even a trace amount of oil vapor can cause a problem, three stage filtration is necessary. Use a Grade DX followed by a Grade BX, and a type CI cartridge.

Physical Properties, Microfibre Filter Cartridges

Temperature Range	-40°F to 300°F (-40°C - 149°C)
Maximum Pressure Differential Across Filter, Inside-to-Outside Flow:	100 psi (7 barg)
Materials of Construction	Borosilicate glass microfibers with fluorocarbon resin binder. Resistant to water, all hydrocarbon and synthetic lubricants.

Retention Efficiency

Grade	Efficiency for 0.01 Micron Particles and Droplets
DX	93%
BX	99.99%

Balston Filter Cartridges

Balston provides two grades of coalescing filter cartridges, Grade DX and Grade BX. Singly or in tandem, these filters satisfy all requirements for removing liquid and solid contaminants from compressed air. Balston also has an activated carbon adsorbent CI-type cartridge for the removal of trace oil vapors from a compressed air line. The activated carbon cartridge is Grade 000.

How to Select the Filter Cartridge and Housing

- 1 Decide which grade(s) of filter cartridges fits the application (see selection boxes at left).
- 2 Select the filter housing with a port size equal to the line size where the filter is to be located.
- 3 For a new installation in which the line size has yet to be selected, determine the gas flow rate and pressure at the point where the filter will be located, and then refer to the flow chart on the reverse side of this data sheet. NOTE: The filter port size must be equal to or larger than the line size (when specified).

How to Order the Filter Assembly

- 1 Build your own custom filter assembly using the guideline matrix on Page 16 and specify your model number. Example: 1/2" filter with DPI and Auto Drain with Grade DX Filter = 6004N-01A-DX.
- 2 Each assembly is shipped with the filter cartridge installed. To order additional filter cartridges, indicate the model number of the cartridges, and the grade. Examples 050-05-DX, 050-05-BX. The grade used for Type CI cartridges is 000 (CI-100-12-000).

Note: Assemblies with CI Cartridges are shipped with the adsorbent cartridge wrapped separately. This shipping method prolongs the life of the cartridge.

Compressed Air Filters

Stainless Steel Filters for Harsh Environments

Models 6102, 6002, 6904

The 6102 and 6002 series models are 1/4" line size filters designed for lower flow systems and installations with space limitations. It is offered with two drain options, a manual drain or an auto float drain for maintenance free operation. The model 6904 offers 1/2" inlet and outlet connections, for applications requiring 1/2" pipe with space limitation requirements.



Models 6102, 6002, 6904

Model 6004

Model 6004

The 6004 series models are 1/2" line size filters designed for moderate flow rate systems. This series has increased liquid holding capacity which safeguards sensitive end use points from system upsets and morning start ups.

Models 6006 and 6008

The 6006 and 6008 series models are 3/4" and 1" line size filters respectively. These are designed for high flow rate systems servicing multiple end use points. These are also offered with a high capacity auto float drain option.



Models 6006 and 6008

How to Order the Filter Assembly*

Build your own custom filter assembly using the guideline matrix below and specify your model number. Example: 1/2" filter with Auto Drain and Grade DX Filter = 6004N-0A1-DX.

*Consult Factory. Not all configurations are available.

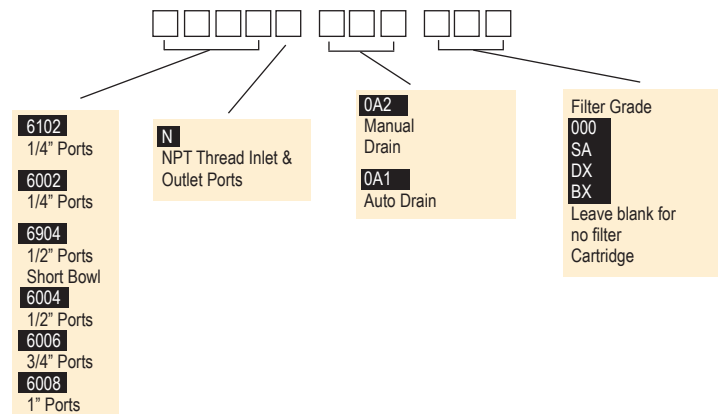

Compressed Air Filters

Stainless Steel Filters for Harsh Environments

Compressed Air Filters

Flow Rates

Filter Housing Model	Port Size	Filter Cartridge Grade	Flow rates SCFM (Nm ³ /hr), at 7 psi drop at indicated line pressure (over 3 stages). Refer to Principal Specification Charts in each product data sheet for maximum pressure rating of each housing								
			2 (0.14)	20 (1.4)	40 (3)	80 (6)	100 (7)	125 (9)	150 (10)	200 (14)	250 (17)
6102N	1/4"	DX	3.5 (6)	8 (13)	11 (18)	20 (33)	25 (42)	30 (50)	36 (60)	---	---
		BX	1 (2)	2 (3)	3.5 (6)	5.7 (10)	6.8 (11)	8 (13)	10 (17)	---	---
6002N	1/4"	DX	9 (15)	19 (32)	39 (66)	51 (87)	63 (107)	76 (129)	90 (153)	117 (199)	145 (246)
6904N	1/2"	BX	3 (5)	8 (14)	11 (19)	21 (36)	25 (42)	31 (53)	36 (61)	47 (80)	58 (99)
		CI	2 (3)	5 (8)	7 (12)	12 (20)	15 (25)	18 (31)	22 (37)	28 (48)	35 (59)
		SA	---	8 (14)	11 (19)	21 (36)	25 (42)	31 (53)	36 (61)	---	---
6004N	1/2"	DX	19 (32)	41 (70)	65 (110)	113 (192)	137 (233)	166 (181)	196 (333)	257 (437)	316 (537)
		BX	9 (15)	19 (32)	30 (51)	51 (87)	63 (107)	76 (129)	90 (153)	117 (199)	145 (246)
		CI	6 (10)	12 (20)	19 (32)	32 (54)	39 (66)	48 (82)	56 (95)	73 (124)	90 (153)
		SA	---	19 (32)	30 (51)	51 (87)	63 (107)	76 (129)	90 (153)	---	---
6006N	3/4"	DX	37 (63)	78 (133)	123 (209)	214 (364)	259 (440)	315 (535)	371 (630)	484 (822)	596 (1013)
		BX	10 (17)	21 (36)	34 (58)	56 (95)	70 (119)	85 (144)	101 (172)	131 (223)	162 (275)
		CI	8 (14)	16 (27)	26 (44)	44 (75)	53 (90)	65 (110)	76 (129)	99 (168)	122 (207)
		SA	---	21 (36)	34 (58)	56 (95)	70 (119)	85 (144)	101 (172)	---	---
6008N	1"	DX	55 (93)	115 (195)	181 (308)	314 (533)	380 (646)	463 (787)	546 (928)	711 (1208)	877 (1490)
		BX	11 (19)	23 (39)	37 (63)	64 (109)	77 (131)	94 (160)	111 (189)	144 (245)	178 (302)
		CI	10 (17)	20 (34)	32 (54)	56 (95)	67 (114)	82 (139)	96 (163)	125 (212)	154 (262)
		SA	---	23 (34)	37 (70)	64 (116)	77 (144)	94 (177)	111 (209)	---	---

Sterile Air Filters

Balston grade SA filter cartridges, rated at 99.9999+% efficiency for 0.01 micron particles, is at least 30 times better than the accepted standard for sterile air filters developed by independent research organizations in the U.S. and U.K. (request bulletin TI-105A for a detailed discussion on Balston filter efficiency rating procedure, and Bulletin TI-935 for an independent test report on balstonSterile Air Filters). Balston Sterile Air Filters are in full compliance with the requirements of the FDA.

Steam Sterilization Procedure

In installations where the sterile air filter requires steam sterilization, we recommend the following procedures:

The steam sterilization pressure should not exceed 60 psig (4 barg). Preferably, it should be held to 40 psig (3 barg) or less. A typical sterilization cycle is 30 psig (2 barg) steam for 30 minutes. Steaming time can be increased as desired without harm to the filter cartridges. The steam flow should not exceed the normal air flow for the unit. To ensure no buildup of condensate in the housing, condensate should be drained from the filter by a condensate drain valve during the steaming process. The cleanliness of the steam is an important factor influencing the life of the Sterile Air Filter cartridges. Parker strongly recommends using Model 23 Steam Filters to ensure optimum operating life. When autoclaving, the Grade SA filter cartridges will tolerate temperatures to 300°F (149°C) in dry gas. Viton or other heat resistant seals should be used in the housing.

Compressed Air Filters

Stainless Steel Filters for Harsh Environments

Principal Specifications

Model	6102	6002	6904	6004	6006	6008
Port Size	1/4" NPT	1/4" NPT	1/2" NPT	1/2" NPT	3/4" NPT	1" NPT
Materials of Construction						
Head	316 Stainless Steel	304 Stainless Steel	→	→	→	→
Bowl	316 Stainless Steel	304 Stainless Steel	→	→	→	→
Internals	Acetal	Stainless Steel	→	→	→	→
Seals	Viton	Buna-N Food Grade	→	→	→	→
Maximum Temperature	140°F (60°C) (1)	120°F (49°C) (1)	→	→	→	→
Maximum Pressure	150 psig (12.1 barg) (2)	175 psig (10.3 barg) (2)	→	→	→	→
Minimum Pressure	15 psig (1 barg) (3)	15 psig (1 barg) (3)	→	→	→	→
Shipping Weight	3.5 lbs. (1.6 Kg)	3.5 lbs. (1.6 Kg)	3.5 lbs. (1.6 Kg)	4.0 lbs. (1.8 Kg)	11 lbs. (4.9 Kg)	12 lbs. (5.4 Kg)
Dimensions	1.5"W x 4.2"L (3.8cm x 11.7cm)	3"W X 7"L (7cm X 18cm)	3"W X 7"L (7cm X 18cm)	3"W X 10"L (7cm X 25cm)	4"W X 10"L (10cm X 25cm)	4"W X 12"L (10cm X 30cm)

Notes:

- 1 Max. temperature with auto drain. Max. temperature with manual drain is 275°F (135°C). 2 Max. pressure with auto drain. Max. pressure with manual drain is 250 psi (17 barg). 3 Required for proper operation of auto drain.

Ordering Information For assistance, call toll-free at 1-800-343-4048 8AM to 5PM Eastern Time

Assembly Ordering Information					
Model P/N	Filter Tube	Drain (Manual)	Drain (Auto. Float)	Mounting Bracket (stainless steel)	
6102N-0A0-(?X)	070-063-(?X)	SAP05481	N/A	N/A	
6102N-0A1-(?X)	070-063-(?X)	N/A	C02-2392	N/A	
6002N-0A2-(?X)	100-12-(?X)	C01-0108	N/A	C01-0094	
6002N-0A1-(?X)	100-12-(?X)	N/A	C01-0109	C01-0094	
6002N-0A2-SA	100-12-SA	C01-0108	N/A	C01-0094	
6002N-0A2-000	CI-100-12-000	C01-0108	N/A	C01-0094	
6904N-0A2-(?X)	100-12-(?X)	C01-0108	N/A	C01-0094	
6904N-0A2-(?X)	100-12-(?X)	N/A	C01-0109	C01-0094	
6904N-0A2-SA	100-12-SA	C01-0108	N/A	C01-0094	
6904N-0A2-000	CI-100-12-000	C01-0108	N/A	C01-0094	
6004N-0A2-(?X)	100-18-(?X)	C01-0108	N/A	C01-0094	
6004N-0A1-(?X)	100-18-(?X)	N/A	C01-0109	C01-0094	
6004N-0A2-SA	100-18-SA	C01-0108	N/A	C01-0094	
6004N-0A2-000	CI-100-18-000	C01-0108	N/A	C01-0094	
6006N-0A2-(?X)	200-176-(?X)	C01-0108	N/A	C01-0094	
6006N-0A1-(?X)	200-176-(?X)	N/A	C01-0109	C01-0094	
6006N-0A2-SA	200-176-SA	C01-0108	N/A	C01-0094	
6006N-0A2-000	200-176-000	C01-0108	N/A	C01-0094	
6008N-0A2-(?X)	200-185-(?X)	C01-0108	N/A	C01-0094	
6008N-0A1-(?X)	200-185-(?X)	N/A	C01-0109	C01-0094	
6008N-0A2-SA	200-185-SA	C01-0108	N/A	C01-0094	
6008N-0A2-000	200-185-000	C01-0108	N/A	C01-0094	
Replacement Filter Cartridge Ordering Information					
Model P/N	6102	6002/6904	6004	6006	6008
Replacement Filter Cartridges					
Number required	1	1	1	1	1
Box of 5	5/070-063-(?X)	5/100-12-(?X)	5/100-18-(?X)	5/200-176-(?X)	5/200-185-(?X)
Box of 10	070-063-(?X)	100-12-(?X)	100-18-(?X)	200-176-(?X)	200-185-(?X)
Box of 10	070-063-SA	100-12-SA	100-18-SA	200-176-SA	200-185-SA
CI Cartridges (box of 1)	---	CI100-12-000	CI100-18-000	CI200-176-000	CI200-185-000

Compressed Air Filters

Disposable Filter Silencers

Compressed Air Filters

Models 9955-05-DX, 9955-11-DX, 9955-12-DX, AR-009-DX

Balston Filter/Silencers for air exhausts offer the combination of unusually effective sound attenuation and filtration of all visible oil mist from the exhaust air. The Filter/Silencers are available in 1/8", 1/4", 1/2", and 3/4" port sizes. They contain a Grade DX Microfiber Filter Cartridge sealed into a molded nylon or steel holder.

Balston Filter/Silencers are remarkably efficient sound mufflers, far more efficient than the felts, pleated paper, sintered plastic, and sintered metal products commonly used in other exhaust silencers. A sound attenuation efficiency test comparing a 9955-12-DX, 1/2" Filter/Silencer with a sintered polyethylene silencer is described below.

This silencing efficiency test simulates the action of an air cylinder discharging rapidly to atmosphere. A length of 1/2" line between two ball valves is pressurized with air to a controlled pressure. The upstream valve is closed and then the downstream valve is opened rapidly to discharge the fixed volume of air under pressure to atmosphere. Noise levels were measured at a 3 foot (1 meter) distance with no silencer on the end of the line, with the Balston Filter Silencer, and with competitive silencers.



Model 9955-05-DX



Model 9955-11-DX



Model 9955-12-DX



Model AR-009-DX

Noise Level (dBA)	Upstream Pressure psig (barg)				
	100 (7)	80 (5.5)	60 (4.3)	40 (2.7)	20 (1.5)
Without Silencer	102	102	101	99	95
With Balston Silencer	70	70	69	67	65
With Sintered Polyethylene Silencer	88	88	87	87	81

A similar test of the Model AR-009-DX on a 3/4" air line gave the following results:

Sound Level 3 ft. from 3/4" Air Line Discharging Air At 100 PSIG Atmosphere

Without Silencer	With Model AR-009-DX
113 dBA	94 dBA

Compressed Air Filters

Disposable Filter Silencers

Principal Specifications

Model	9955-05-DX	9955-11-DX	9955-12-DX	AR-009-DX
Inlet Port	1/8" NPT (Male)	1/4" NPT (Male)	1/2" NPT (Male)	3/4" NPT (Female)
Drain Port	1/4" OD Tubing	1/4" OD Tubing	1/4" OD Tubing	1/8" NPT (Female)
Materials of Construction	Borosilicate glass microfibers with fluorocarbon resin binder			
Filter Cartridge	Borosilicate glass microfibers with fluorocarbon resin binder			
Holder	Nylon	Nylon	Nylon	Aluminum
Internals	—	—	—	Aluminum
Maximum Internal Pressure at 110°F (43°F)	100 psig (7 barg) (1)	100 psig (7 barg) (1)	100 psig (7 barg) (1)	100 psig (7 barg) (1)
Maximum Temp. at 0 psig Internal Pressure	260°F (127°C)	260°F (127°C)	260°F (127°C)	300°F (149°C)
Shipping Weight	0.5 lb (0.2 kg)	0.5 lb (0.2 kg)	0.5 lb (0.2 kg)	1 lb (0.5 kg)
Dimensions	1.4" dia. X 2.0"h (4cm X 5cm)	1.4" dia. X 3.0"h (4cm X 8cm)	2.0" dia. X 3.7"h (5cm X 9cm)	3.95" dia. X 5.13"h (10cm X 13cm)

Notes:

1 With the outlet open to atmosphere. Otherwise, maximum internal pressure is 15 psig.

Ordering Information

For assistance, call toll-free at 1-800-343-4048 8AM to 5PM Eastern Time

Model	Description
9955-05-DX, 9955-11-DX, 9955-12-DX	Standard Pack 10 Filter Silencers per box, individually wrapped
AR-009-DX	Complete Assembly with one filter element
Replacement Element for AR-009-DX	
2/BE200-168-DX	Boxes of 2
BE200-168-DX	Boxes of 10

Table 1 Flow Rate from Pressured Line through Filter to Atmosphere (cu. ft. per sec.)

Filter Housing Type	100 psig (6.9 barg) Line Pressure	60 psig (4.1 barg) Line Pressure	20 psig (1.4 barg) Line Pressure
9955-05-DX	3 (4.9)	1.2 (2.5)	0.2 (0.7)
9955-11-DX	10 (16.2)	4 (8.2)	0.7 (0.5)
9955-12-DX	35 (57)	14 (29)	2.2 (1)
AR-009-DX	105 (171)	42 (86)	6.6 (4)

Low Flow, Compact Compressed Air Filters



Balston 92-800 Series Compressed Air and Gas Filters

Safeguard critical end use points from water, oil, rust and pipescale. The 92-800 series compressed air filters are small and compact making them ideal for portable pneumatics, instrumentation, and other applications requiring small pneumatic components.

The 92-800 Series are available with anodized aluminum heads and polycarbonate bowls, anodized aluminum bowls, or pyrex glass bowls. Capable of up to 250 PSIG and 250°F, these filters can be applied to the most demanding applications. High efficiency filtration media is available from 93% at 0.01 micron to 99.9999+% at 0.01 micron.

The 92-800 series are available with 1/4" and 1/2" NPT connections.



Applications

These filters are ideal for safeguarding critical production equipment from corrosive compressor condensate that can cause catastrophic failures and unexpected shutdowns. Ideal applications are:

- Instrumentation
- Air actuators and air cylinders
- Pneumatic packaging machines
- Pneumatic conveyors
- Air operated production equipment
- Air operated lifts

Product Features

- Small compact design
- Anodized aluminum with polycarbonate, Pyrex, or aluminum bowls
- Continuously trap and drain liquids
- Remove up to 99.9999+% of 0.01 micron particles of oil, water, and dirt from compressed air and other gases
- High flow rate capacity
- Low pressure drop

The Parker Balston 92-800 Series offer the best protection to all your pneumatic equipment and instrumentation. These high efficiency filtration systems will eliminate costly maintenance and unexpected downtime due to contaminated compressed air.

Low Flow, Compact Compressed Air Filters

Principal Specifications and Ordering Information



92-810A



92-810

Filter Housing Model	Port Size	Filter Cartridge Grade	Flow rates SCFM (Nm ³ /hr), at 2 psi drop at indicated line pressure. Refer to Principal Specification Charts in each product data sheet for maximum pressure rating of each housing								
			2 (0.14)	20 (1.38)	40 (2.76)	80 (5.52)	100 (6.9)	125 (8.6)	150 (10.3)	200 (13.8)	250 (17.2)
Series 92-810/2	1/4"	DX	12 (20.4)	26 (44.2)	40 (68.0)	70 (118.9)	85 (144.4)	103 (175.0)	122 (207.3)	159 (270.1)	196 (333.0)
	1/2"	BX	3 (5.1)	7 (11.9)	10 (17.0)	18 (30.6)	22 (37.4)	27 (45.9)	32 (54.4)	41 (69.7)	51 (86.6)

Principal Specifications

Model (1)	92-810A	92-810
Port Size	1/4" NPT	1/4" NPT
Material of Construction		
Head	Aluminum	Aluminum
Bowl	Aluminum	Polycarbonate
Internals	Aluminum	Aluminum
Seals	Buna-N Grade	Buna-N Grade
Maximum Temperature	250°F (121°C)	130°F (54°C)
Maximum Pressure	250 psig (17 barg)	150 psig (10 barg)
Shipping Weight	2 lbs. (0.9 kg)	2 lbs. (0.9 kg)
Dimensions	2.75"W x 5.64"L (7cm W x 14cm L)	2.75"W x 5.64"L (7cm W x 14cm L)

Ordering Information for assistance, please call 1-800-343-4048 8AM to 5PM Eastern Standard Time

Model P/N (2)	Description	Replacement Cartridge	
		Box of 2	Box of 10
92-810A	1/4" NPT Ports with Aluminum Bowl	2/100-12-?X	100-12-?X
92-812A	1/2" NPT Ports with Aluminum Bowl	2/100-12-?X	100-12-?X
92-810	1/4" NPT Ports with Polycarbonate Bowl	2/100-12-?X	100-12-?X
92-812	1/2" NPT Ports with Polycarbonate Bowl	2/100-12-?X	100-12-?X

Notes:

- 1 For 1/2" NPT Ports, order 92-812
- 2 Filter housings are not supplied with filter cartridges

Compressed Air Filters

Filter Regulators

Compressed Air Filters

Filter-Regulator Combinations

Balston Filter-Regulators combine a high efficiency coalescing filter with a high quality pressure regulator. Air flows through the filter, then to the pressure regulator. The filter is a Balston coalescing compressed air filter (Grade BX) and will completely remove oil, water, and dirt from compressed air and other compressed gases. Flow direction through the element is inside-to-outside for optimum oil and water removal. An automatic drain is installed on the 3/8", 1/2", and 3/4" models offering maintenance-free operation. Pressure gauges are standard and are available in up to 4 different ranges (see ordering information).



AFR-940, AFR-940A



12E Series

Control Characteristics

Model AFR-940, AFR-940A

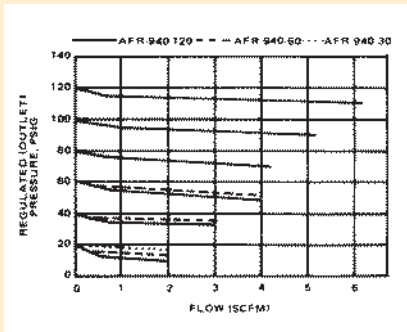

Model 12E

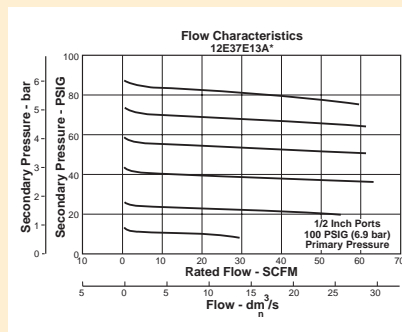

Compressed Air Filters

Filter Regulators

Principal Specifications

Model	AFR-940	AFR-940A	12E37	12E47
Port Size	1/4" NPT	1/4" NPT	1/2" NPT	3/4" NPT
Gauge Ports	1/8" NPT	1/8" NPT	1/4" NPT	1/4" NPT
Materials of Construction				
Head	Anod. Alum.	Anod. Alum.	Zinc	Zinc
Bowl	Polycarb.	Anod. Alum.	Zinc	Zinc
Bonnet	Polycarb.	Polycarb.	Plastic	Plastic
Internals	Brass/Buna	Brass/Buna	Zinc/Nitrile	Zinc/Nitrile
Maximum Temperature	220°F (104°C)	220°F (104°C)	125°F (52°C)	125°F (52°C)
Maximum Pressure	150 psig (10.3 barg) (2)	250 psig (17.2 barg) (2)	250 psig (17.2 barg) (2)	250 psig (17.2 barg) (2)
Minimum Pressure	—	—	15 psig/1.03 barg (1)	15 psig/1.03 barg (1)
Shipping Weight	0.5 lbs. (0.2 kg)	0.5 lbs. (0.2 kg)	2.5 lbs. (1.1 kg)	2.5 lbs. (1.1 kg)
Dimensions	1.2"W X 6"L (3cm X 15cm)	1.2"W X 6"L (3cm X 15cm)	3.25"W X 13"L (8cm X 33cm)	3.25"W X 13"L (8cm X 33cm)

Ordering Information

For assistance, call toll-free at 1-800-343-4048 8AM to 5PM Eastern Time

Model	AFR-940	AFR-940A	12E37	12E47
Control Gauge Pressure Range				
0-30 psig	AFR-940-30	AFR-940A-30	see ordering matrix below	→
5-60 psig	AFR-940-60	AFR-940A-60	see ordering matrix below	→
10-130 psig	AFR-940-130	AFR-940A-130	see ordering matrix below	→
Auto. Drain	N/A (1)	N/A (1)	Included (1)	Included (1)
Replacement Filter Cartridges				
Number Required	1	1	1	1
Box of 5	5/050-05-BX	5/050-05-BX	5/130-14-BX	5/130-14-BX
Box or 10	050-05-BX	050-05-BX	130-14-BX	130-14-BX
Mounting Bracket	11536	11536	PS807P	PS807P

Notes:

- 1 Minimum operating pressure for automatic drain is 15 psig (1.03 barg).
- 2 Maximum pressure ratings are for tem-

peratures to 130°F (54°C). Please consult the factory for maximum pressure ratings at elevated temperatures.

How to Order

To order product with desired port size and Regulating Pressure Range, select the indicator digits from the matrix (at right). This will complete the entire model number which is needed to place an order.

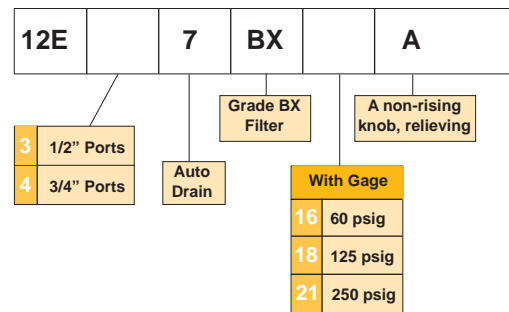

Compressed Air Filters

Mist Lubricators

Compressed Air Filters

Model 17L Series

Many pneumatic system components and most tools require oil lubrication for proper operation and long service life. This lubricant is typically carried by the air stream. Too little oil can cause excessive wear and premature failure. Too much oil is wasteful and can become a contaminant. Use of the proper lubricator can greatly extend the life of expensive downstream pneumatic equipment.

The 17L Series Micro-Mist Lubricators offer proportional oil delivery over a wide range of air flows. The precision needle valve assures repeatable oil delivery and provides simple adjustment of delivery rate. They are designed to generate oil droplets of 5 microns or smaller downstream to lubricate systems having complex piping arrangements. The 17L series are ideal for low and high flow applications with changing air flow.



17L Series

How to Select the Correct Lubricator

Once the required flow is determined for a pneumatic application, the lubricator can be selected by using the flow chart. To read the lubricator flow chart, first determine the inlet pressure that will be used. Find the appropriate pressure curve on the graph. Each graph will contain three pressure curves. If the required inlet pressure is not on the graph, interpolate a similar curve for the required pressure.

Next, determine the acceptable pressure drop across the lubricator and locate it on the vertical axis. Find the intersection point of the acceptable pressure drop and the inlet pressure curve. At this point, follow a vertical path downward to view the flow in SCFM. If the flow is too low, select a larger port size or body size to give the required flow. If the flow is higher than necessary, select a smaller port size or body size to give the required flow.

Model 17L22B

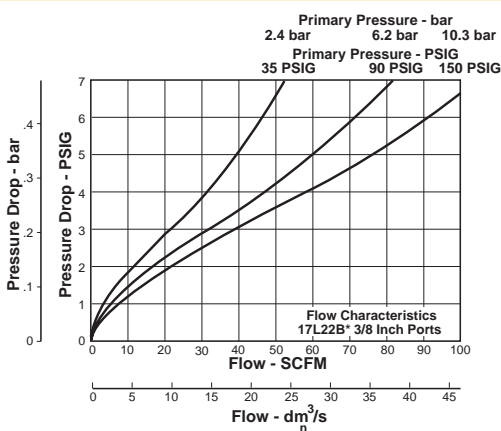

Model 17L32B and 17L42B

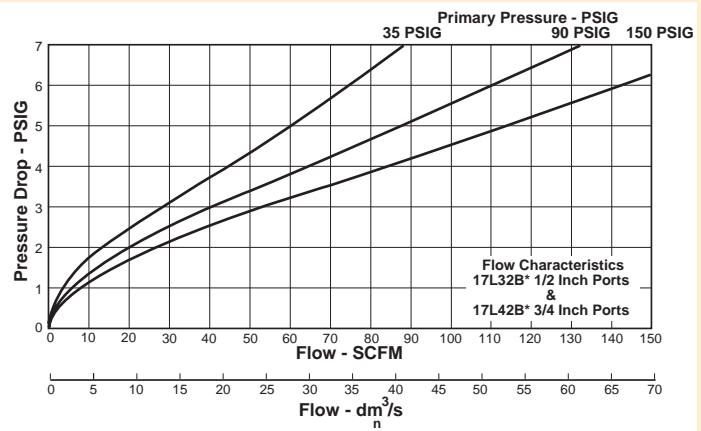

Compressed Air Filters

Mist Lubricators

Principal Specifications

Model	17L22BE	17L32BE	17L42BE
Port Size	3/8" NPT	1/2" NPT	3/4" NPT
Gauge Ports	1/4" NPT	1/4" NPT	1/4" NPT
Materials of Construction			
Head	Zinc	Zinc	Zinc
Bowl	Polycarbonate	Polycarbonate	Polycarbonate
Bowl Guard	Steel	Steel	Steel
Collar	Plastic	Plastic	Plastic
Seal	Nitrile	Nitrile	Nitrile
Sight Dome	Polycarbonate	Polycarbonate	Polycarbonate
Sight Gage	Polyamide	Polyamide	Polyamide
Maximum Temperature	125°F (52°C)	125°F (52°C)	125°F (52°C)
Maximum Pressure	150 psig (10.3 barg)	150 psig (10.3 barg)	150 psig (10.3 barg)
Minimum Pressure	15 psig (1.03 barg)	15 psig (1.03 barg)	15 psig (1.03 barg)
Shipping Weight	1.9 lbs. (0.9 kg)	1.9 lbs. (0.9 kg)	1.9 lbs. (0.9 kg)
Dimensions	3.25"W X 9.27"L (85mm X 235mm)	3.25"W X 9.27"L (85mm X 235mm)	3.25"W X 9.27"L (85mm X 235mm)

Ordering Information

For assistance, call toll-free at 1-800-343-4048 8AM to 5PM Eastern Time

Model	17L22BE (3/8"NPT)	17L32BE (1/2"NPT)	17L42BE (3/4"NPT)
Service Kit	PS748P	PS748P	PS748P

Compressed Air Filters

Selection Chart Prep-Air® II Air Preparation Units

Compressed Air Filters

Product Selection Chart

Basic Unit	Series	Port Size (inches)											Bowls			Capacity	Elements (Micron)	Page		
		1/8	1/4	3/8	1/2	3/4	1	1-1/4	1-1/2	2	2-1/2	3	Poly	Metal	Metal SG		5			
FILTERS	FF10				X										316 Stainless Steel			4 oz. (113 ml)	Standard	37
	10F	X	X												X	X	X	1 oz. (28 ml)	Grade 6 Std., Grade 10 Opt.	39
COALESCERS	FF501		X												316 Stainless Steel			1 oz. (28 ml)	Grade 6	41
	FF11				X										316 Stainless Steel			4 oz. (113 ml)	Grade 6	43

Basic Unit	Series	Port Size (inches)							Spring	Page
		1/8	1/4	3/8	1/2	3/4	1	1-1/2	125	
REGULATORS	FR364		X						Standard	45
	05R		X	X					Standard	47
	FR10				X				Standard	49
	07R			X	X	X			Standard	51
	P3NR					X	X	X	Standard	53

*Sight gauge

Compressed Air Filters

Selection Chart Prep-Air® II Air Preparation Units

Product Selection Chart

Basic Unit	Series	Port Size							Bowls			Capacity	Elements (Micron)	Spring Range	Page
		1/8	1/4	3/8	1/2	3/4	1	1-1/2	Poly	Metal	Metal SG		5	125	
F I L T E R / R E G U L A T O R S	14E	X	X						X	X	N/A	1 oz. (28 ml)	Standard	Standard	55
	FB548		X						316 Stainless Steel			1 oz. (28 ml)	Standard	Standard	57
	06E		X	X	X				X	X	X	4.4 oz. (125 ml)	Standard	Standard	59
	FB11				X				316 Stainless Steel			4 oz. (113 ml)	Standard	Standard	61

*Sight gauge

Compressed Air Filters

Air Preparation Units - Drains

Automatic Pulse Drain

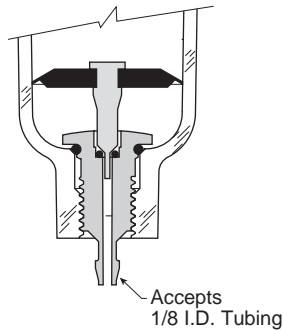

(Spitter Drain)

The diaphragm in this drain pulses when there is a pressure differential such as a valve cycling or cylinder stroking downstream. This action flexes the diaphragm and allows the filter to drain the entrapped water.

Automatic Float Drain

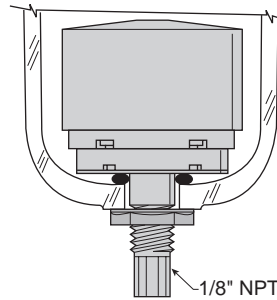

The float internal to this drain rises with increased liquid level. When the float rises, it opens a seat area allowing the trapped liquids to drain through the bottom. A manual override can be pushed in the bottom of the drain to unseat the float if particulates create a block.

Compressed Air Filters

Air Preparation Units - FF10 Filter - Standard 1/2" NPT Ports

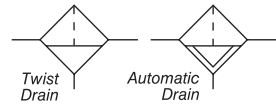

Features

- Stainless steel construction handles most corrosive environments.
- Meets NACE specifications MR-01-75/ISO 15156.
- 1/8" female threaded drain.
- High Flow: 1/2" - 70 SCFM (119 Nm³/hr)[§]

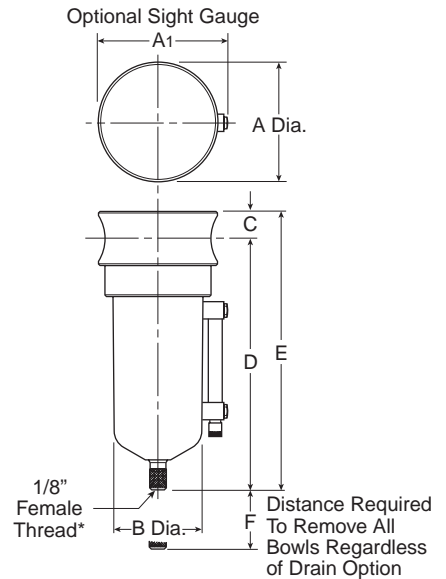

Port Size	NPT without sight gauge		NPT with sight gauge	
	Manual Twist Drain	Automatic Float Drain	Manual Twist Drain	Automatic Float Drain
1/2"	FF10-04DGSS	FF10-04DGRSS	FF10-04WGSS	FF10-04WGRSS

F10 Filter Dimensions		
A 2.38 (60)	A1 2.50 (64)	B 1.75 (44)
C .56 (14)	D 5.00 (127)	E 5.56 (141)
F 2.12 (54)		

[§] SCFM = Standard cubic feet per minute at 90 PSIG inlet and 5 PSIG pressure drop.
Nm³/hr= Normal cubic meters per hour.

inches
(mm)

Ordering Information

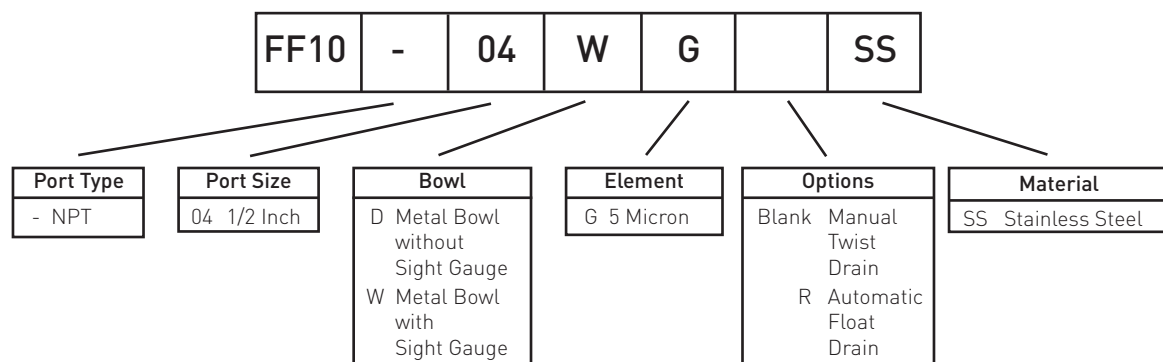

Compressed Air Filters

Air Preparation Units - FF10 Air Line Filters

Technical Information

Compressed Air Filters

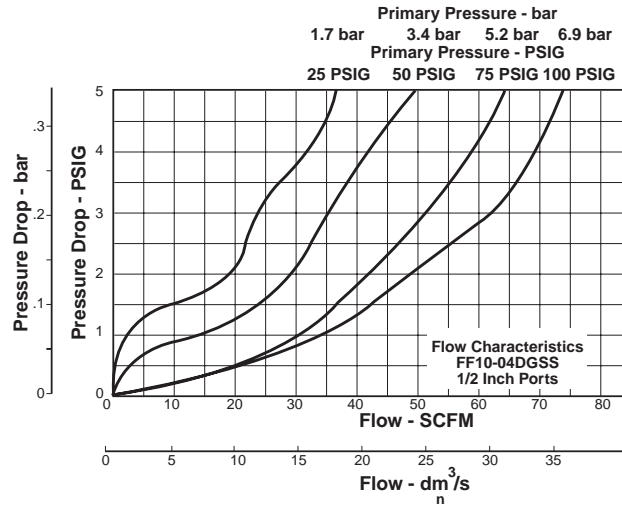

FF10 Filter Kits & Accessories

Drain Kit -	
Automatic Float Drain	SA602MDSS
Manual Twist Drain-	
Small (Old)	SA600Y7-1SS
Large (New)	SAP05481
Filter Element Kits -	
Particulate (5 Micron) Element	EK55G
Pipe Nipple - 1/2" 316 Stainless Steel	616A28-SS

Specifications

Bowl Capacity	4.0 Ounces (28 ml)
Filter Rating	5 Micron
Sump Capacity	1.7 Ounce
Port Threads	1/2 Inch
Pressure & Temperature Ratings -	
Manual Twist Drain (D-Bowl)	0 to 300 PSIG (0 to 20.7 bar)
	0°F to 180°F (-18°C to 82°C)
Manual Twist Drain (W-Bowl)	0 to 250 PSIG (0 to 17.2 bar)
	0°F to 150°F (-18°C to 66°C)
Automatic Float Drain	15 to 175 PSIG (1 to 12 bar)
	40°F to 125°F (4°C to 52°C)

Note: Air must be dry enough to avoid ice formation at temperatures below 32°F (2°C).

Weight

Materials of Construction

Body	316 Stainless Steel
Bowls	316 Stainless Steel
Deflector	Acetal
Drain	316 Stainless Steel
Element Holder	Acetal
Filter Element	Polyethylene
Seals	Fluorocarbon
Sight Gauge	Isoplast

Compressed Air Filters

Air Preparation Units - 10F Coalescing Filters - Miniature 1/8", 1/4" Basic 1/8" Body

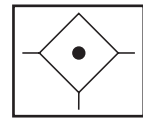

Features

- Removes liquid aerosols and sub-micron particles.
- Liquids gravitate to the bottom of the element and will not re-enter the airstream.
- Oil free air for critical applications, such as air gauging and pneumatic instrumentation and controls.
- Interchangeable twist and automatic pulse drains.
- Grade 6 element, 99.97% DOP efficiency.
- High Flow:
 - Grade 6 Element
 - 1/8" – 17 SCFM (29 Nm³/hr) §
 - 1/4" – 20 SCFM (34 Nm³/hr) §
 - Grade 10 Element
 - 1/8" – 19 SCFM (32 Nm³/hr) §
 - 1/4" – 24 SCFM (41 Nm³/hr) §

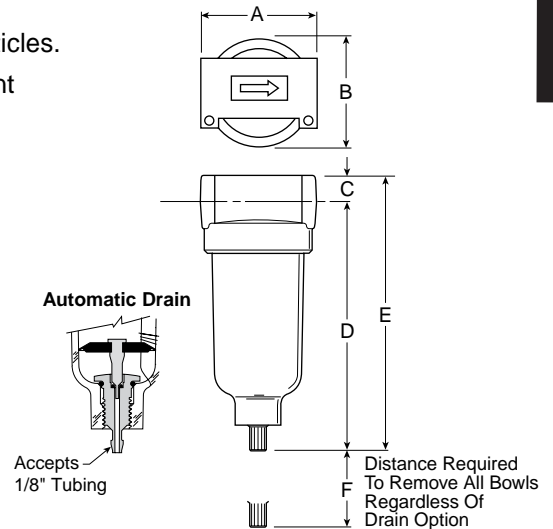

Port Size	NPT	
	Twist Drain	Automatic Pulse Drain
Poly Bowl ‡		
1/8"	10F01E*	10F05E*
1/4"	10F11E*	10F15E*
Metal Bowl without Sight Gauge		
1/8"	10F03E*	10F07E*
1/4"	10F13E*	10F17E*

10F Coalescing Filter Dimensions		
A 1.69 (43)	B 1.56 (39,6)	C 0.39 (10)
D 3.82 (97)	D* 3.67 (93)	E 4.21 (107)
E* 4.06 (103)	F 1.60 (41)	

Standard part numbers shown bold, with Grade 6 Elements (for Grade 10 Elements, replace "E" with "H" in the 6th position). For other models refer to ordering information below.

‡ For polycarbonate bowl see Caution on page 2.

§ SCFM = Standard cubic feet per minute.
Nm³/hr = Normal cubic meters per hour.

Inches (mm)

* With Automatic Pulse Drain.

Ordering Information

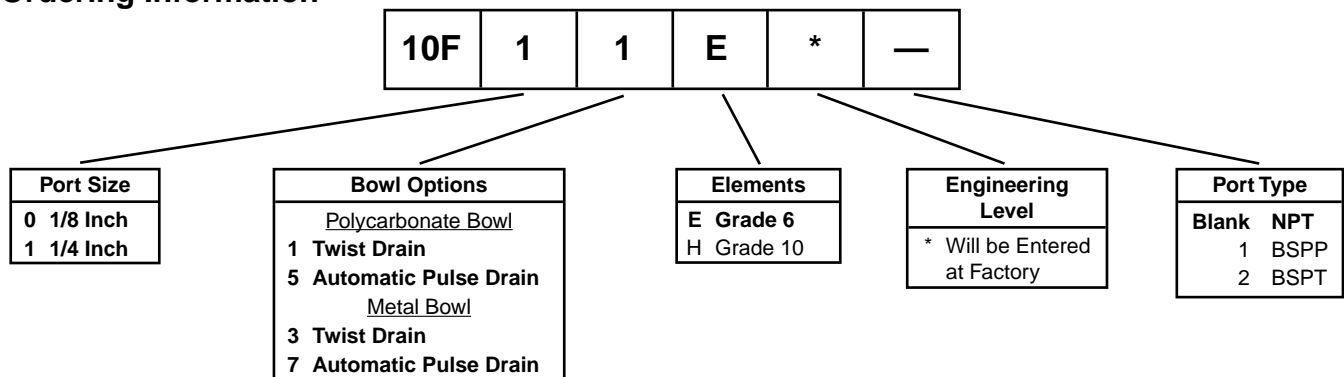

Compressed Air Filters

Air Preparation Units - 10F Coalescing Filters

Technical Information

Compressed Air Filters

Grade 6

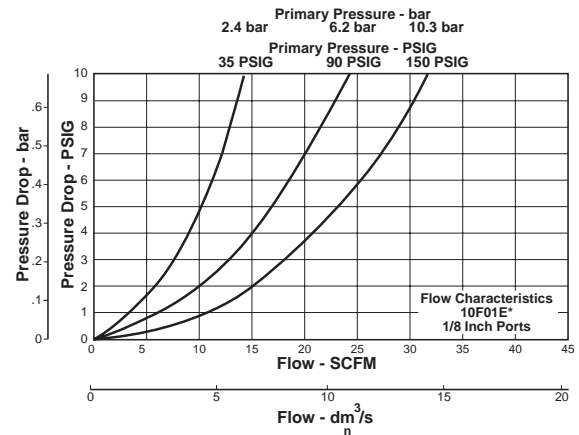
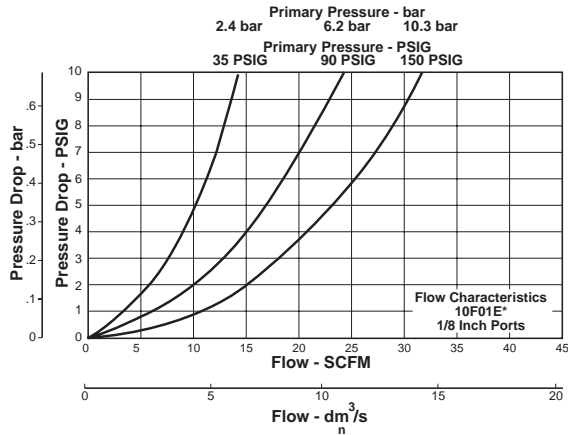

Grade 10

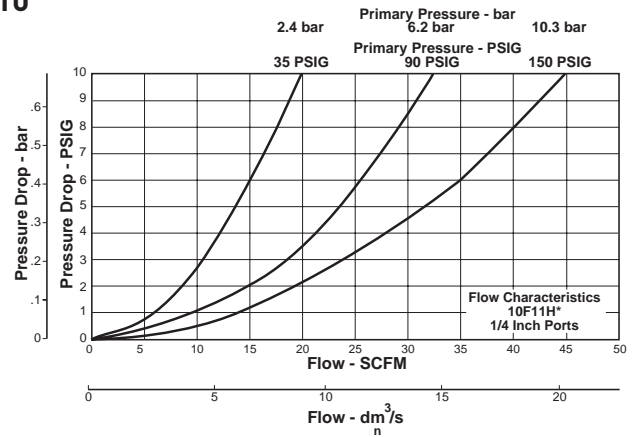
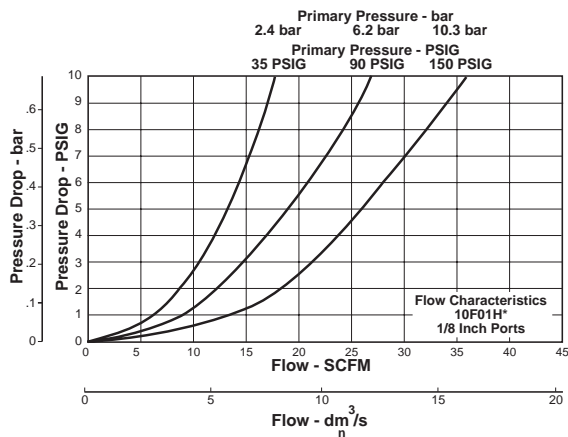

10F Coalescing Filter Kits & Accessories

Bowl Kits -	
Poly Bowl - Automatic Pulse Drain.....	PS408BP
Twist Drain	PS404P
Metal Bowl - Automatic Pulse Drain.....	
Twist Drain	PS447BP
Filter Element Kits - Grade 6 (Standard)	
Grade 10 (Optional)	PS446P
PS456P	
Mounting Bracket Kit	PS417BP

Specifications

Automatic Pulse Drain Tube Barb.....	1/8 Inch
Bowl Capacity	1 Ounce (28 ml)
Operation -	
Normal Operating Pressure Drop	2 PSIG (0.14 bar)
Maximum Recommended Pressure Drop	10 PSIG (1.03 bar)
(Element should be replaced)	
Port Threads	1/8, 1/4 Inch
Pressure & Temperature Ratings -	
Polycarbonate Bowl.....	0 to 150 PSIG (0 to 10.3 bar)
	32°F to 125°F (0°C to 52°C)
Metal Bowl.....	0 to 250 PSIG (0 to 17.2 bar)
	32°F to 175°F (0°C to 80°C)
Automatic Pulse Drain.....	10 to 250 PSIG (0.7 to 17.2 bar)
	at 125°F (52°C) or less
Weight	0.41 lb. (0.18 kg)

Materials of Construction

Body	Zinc
Bowls	Transparent Polycarbonate
	Metal (Zinc) Without Sight Gauge
Drains - Twist Drain -	
Body & Stem	Plastic
Seals.....	Nitrile
Automatic Pulse Drain -	
Piston & Seals.....	Nitrile
Stem, Seat, Adaptor & Washers	Aluminum
Element Holder	Plastic
Filter Element -	
Borosilicate & felt glass fibers	99.97% DOP efficiency
Largest Aerosol Particle Passed (Grade 6)	0.01 Micron
Largest Solid Particle Passed (Grade 6)	0.30 Micron
Seals	Nitrile

Compressed Air Filters

Air Preparation Units

FF501 Coalescing Filter - Miniature 1/4" Ports

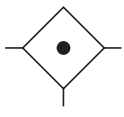

Features

- Stainless steel construction handles most corrosive environments.
- Meets NACE specifications MR-01-75/ISO 15156.
- 1/8" female threaded drain*.
- High Flow: 1/4" - 16 SCFM (27 Nm³/hr)[§]

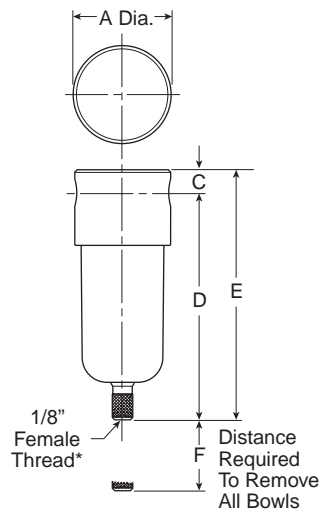

Port Size	NPT
	Manual Twist Drain
1/4"	FF501-02DHSS

F501 Coalescing Filter Dimensions		
A	C	D
1.56 (40)	0.31 (8)	3.69 (94)
E	F	
4.00 (102)	1.58 (40)	

inches
(mm)

Standard part numbers shown bold. For other models refer to ordering information below.

[§] SCFM = Standard cubic feet per minute.
Nm³/hr= Normal cubic meters per hour.

Ordering Information

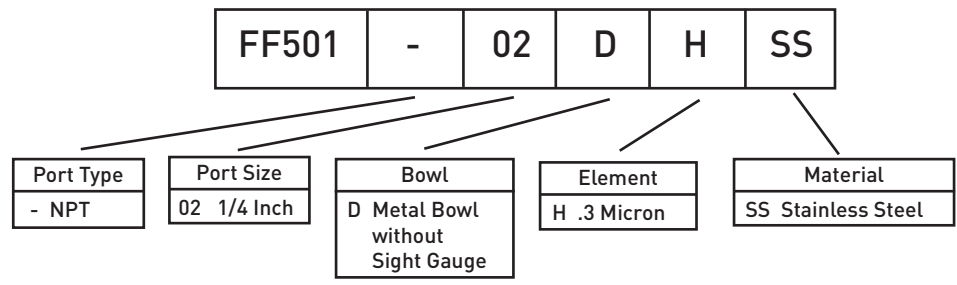

Compressed Air Filters

Air Preparation Units - F501 Series Technical Information

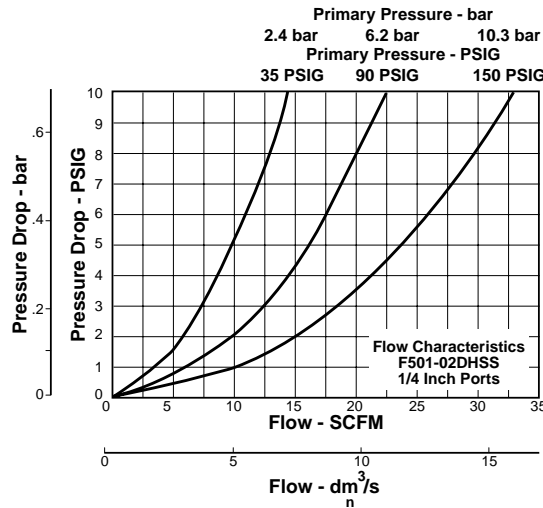

FF501 Filter Kits & Accessories

Filter Element Kits -	
0.3 Micron	EKF31
Manual Twist Drain -	
Small (Old)	SA600Y7-1SS
Large (New)	SAP05481
Pipe Nipple -	
1/4" 316 Stainless Steel	616Y28-SS

Specifications

Bowl Capacity	1.0 Ounces (28 ml)
Filter Rating	0.3 Micron
Port Threads	1/4 Inch
Pressure & Temperature Ratings -	
Manual Twist Drain	0 to 300 PSIG (0 to 20.7 bar) 0°F to 180°F (-18°C to 82°C)

Note: Air must be dry enough to avoid ice formation at temperatures below 32°F (2°C)
 Sump Capacity0.4 Ounce (11 ml)
 Weight 0.6 lb. (0.27 kg)

Materials of Construction

Body	316 Stainless Steel
Bowls	316 Stainless Steel
Drain	316 Stainless Steel
Element Holder	Acetal
Filter Element	Borosilicate Fiber
Seals	Fluorocarbon

Compressed Air Filters

Air Preparation Units - FF11 Coalescing Filter Standard 1/2" Ports

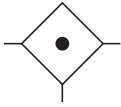

Features

- Stainless steel construction handles most corrosive environments.
- Meets NACE specifications MR-01-75/ISO 15156.
- 1/8" female threaded drain*.
- High Flow: 1/2" - 45 SCFM (77 Nm³/hr)[§]

* Beginning January 2008

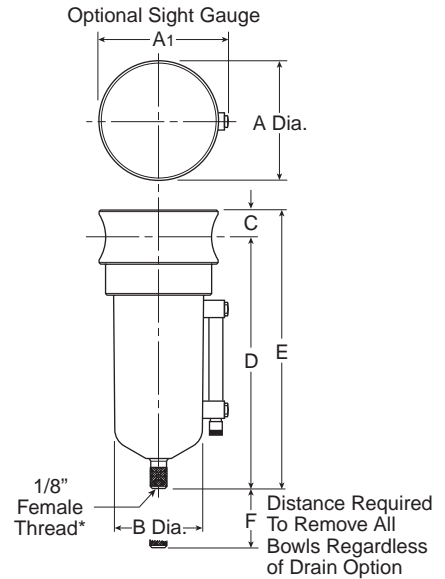

Port Size	NPT without sight gauge		NPT with sight gauge	
	Manual Twist Drain	Automatic Float Drain	Manual Twist Drain	Automatic Float Drain
1/2"	Metal Bowl With Sight Gauge			
	F11-04DJSS	F11-04DJRSS	F11G04WJSS	F11G04WJRSS

F11 Coalescing Filter Dimensions		
A 2.38 (60)	A1 2.50 (64)	B 1.75 (44)
C 0.56 (14)	D 5.00 (127)	E 5.56 (141)
F 2.12 (54)		

Standard part numbers shown bold. For other models refer to ordering information below.

[§] SCFM = Standard cubic feet per minute.
Nm³/hr = Normal cubic meters per hour.

inches
(mm)

Ordering Information

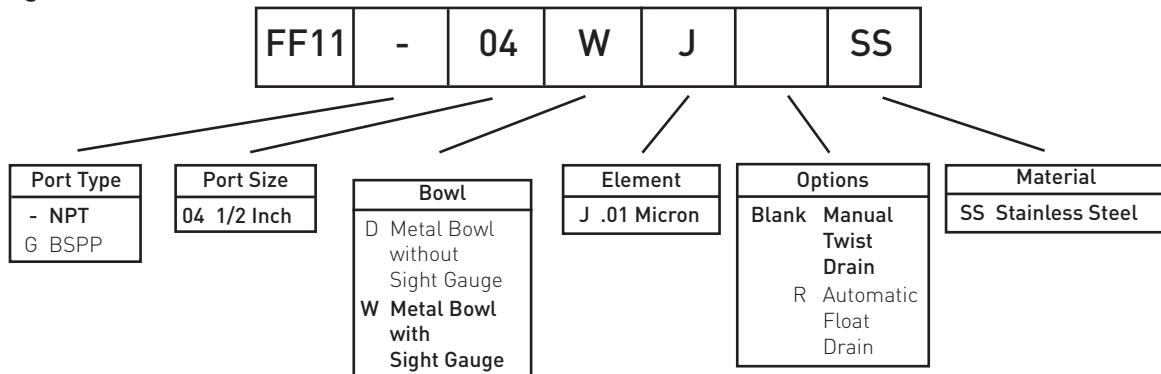

Compressed Air Filters

Air Preparation Units - FF11 Series Technical Information

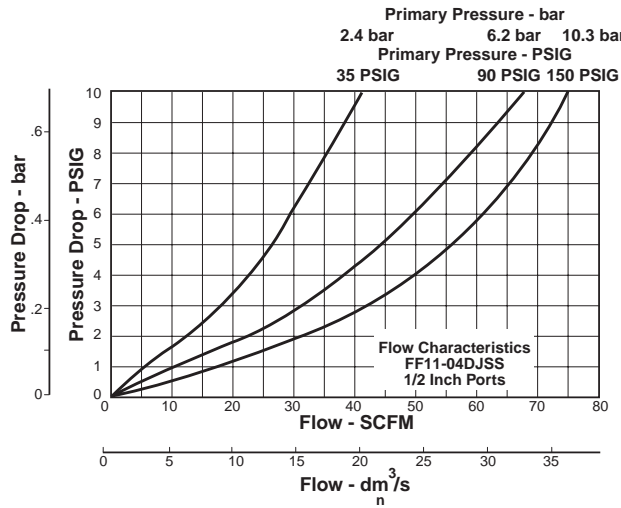

F11 Filter Kits & Accessories

- Drain Kit -
 Automatic Float Drain SA602MDSS
 Manual Twist Drain-
 Small (Old) SA600Y7-1SS
 Large (New) SAP05481
- Filter Element Kits -
 0.3 Micron EKF71
- Pipe Nipple -
 1/2" 316 Stainless Steel 616A28-SS

Specifications

- Bowl Capacity 4.0 Ounces
 Filter Rating 0.01 Micron
 Sump Capacity 1.7 Ounce
 Port Threads 1/2 Inch
- Pressure & Temperature Ratings -
 Manual Twist Drain 0 to 300 PSIG (0 to 20.7 bar)
 0°F to 180°F (-18°C to 82°C)
 Manual Twist Drain (W) 0 to 250 PSIG (0 to 17.2 bar)
 0°F to 150°F (-18°C to 66°C)
 Automatic Float Drain 0 to 175 PSIG (0 to 12 bar)
 40°F to 125°F (4°C to 52°C)

Note: Air must be dry enough to avoid ice formation at temperatures below 32°F (2°C).
 Weight 1.9 lb. (0.85 kg)

Materials of Construction

- Body 316 Stainless Steel
 Bowls 316 Stainless Steel
 Drain 316 Stainless Steel

- Element Holder Acetal
 Filter Element Borosilicate Fiber
 Seals Fluorocarbon
 Sight Gauge Isoplast

FF11 Media Specifications

Grade Designation	Coalescing Efficiency 0.3 to 0.6 Micron Particles	Maximum Oil Carryover ¹ PPM w/w	Micron Rating	Pressure Drop PSID (bar) @ Rated Flow ²		Flow: SCFM @ 3 PSID Operating Pressure 100 PSIG
				Media Dry	Media Wet With 10-20 wt. oil	
6	99.97%	0.008	0.01	1.0 (0.07)	2-3 (0.14-0.21)	??
10	95%	0.85	1.0	0.5 (0.03)	0.5 (0.03)	??

¹Tested per ISO 12500-1 at 40 ppm inlet.
²Add dry + wet for total pressure drop.

Compressed Air Filters

Air Preparation Units - FR364 Regulator -Miniature 1/4" Ports

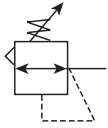

Features

- Stainless steel construction handles most corrosive environments.
- Large diaphragm to valve area ratio for precise regulation and high flow capacity.
- Meets NACE specifications MR-01-75/ISO 15156.
- High Flow: 1/4" - 12 SCFM (20 Nm³/hr)[§]



R364

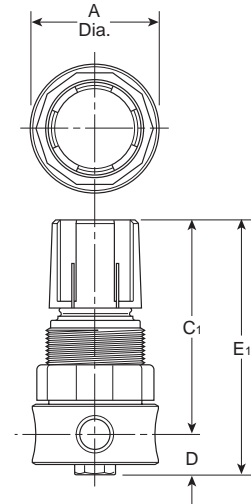

R364

Series	Adjustment Type	Port Size	NPT
FR364	Knob	1/4"	FR364-02CSS

[§] SCFM = Standard cubic feet per minute.
Nm³/hr= Normal cubic meters per hour.

R364 Regulator Dimensions	
A 1.56 (40)	C₁ 2.56 (65)
D 0.50 (13)	E₁ 3.06 (78)

inches (mm)

NOTE: 1.25 Dia. (32mm) hole required for panel mounting.

WARNING

Product rupture can cause serious injury.
Do not connect regulator to bottled gas.
Do not exceed maximum primary pressure rating.

Ordering Information

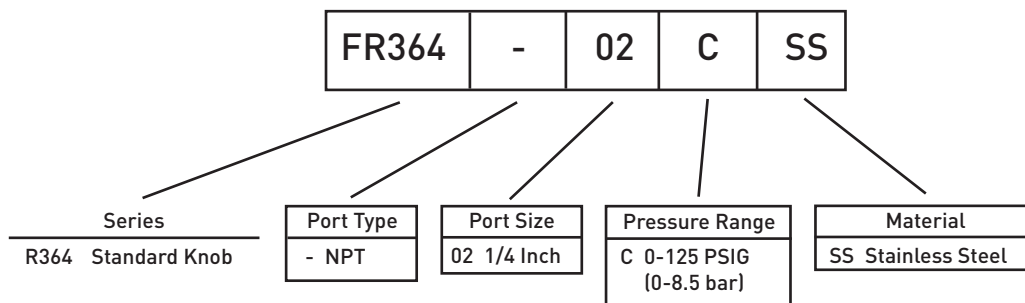

Compressed Air Filters

Air Preparation Units FR364 Air Line Regulators Technical Information

Operation

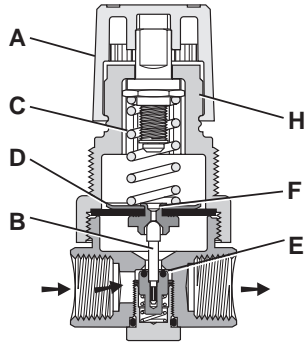

FR364

With the adjusting knob (A) turned fully counter-clockwise (no spring load), and pressure supplied to the regulator inlet port, the valve poppet assembly (B) is closed. Turning the adjusting knob clockwise applies a load to control spring (C). This load causes the diaphragm (D) and the valve poppet assembly (B) to move downward allowing flow across the seat area (E) created between the poppet assembly and the seat. Pressure in the downstream line is sensed below the diaphragm (D) and offsets the load of spring (C). As downstream pressure rises, poppet assembly (B) and diaphragm (D) move upward until the area (E) is closed and the load of the spring (C) and pressure under diaphragm (D) are in balance. A reduced outlet pressure has now been obtained, depending on spring load. Creating a demand downstream, such as opening a valve, results in a reduced pressure under the diaphragm (D). The load of control spring (C) now causes the poppet assembly to move downward opening seat area (E) allowing air to flow to meet the downstream demand. The flow of downstream air is metered by the amount of opening (E).

Should downstream pressure exceed the desired regulated pressure, the excess pressure will cause the diaphragm (D) to move upward against control spring (C), open vent hole (F), and vent the excess pressure to atmosphere through the hole in the bonnet (H). (This occurs in the relieving type regulator only.)

Technical Information

CAUTION:

REGULATOR PRESSURE ADJUSTMENT -

The working range of knob adjustment is designed to permit outlet pressures within their full range. Pressure adjustment beyond this range is also possible because the knob is not a limiting device. This is a common characteristic of most industrial regulators, and limiting devices may be obtained only by special design.

For best performance, regulated pressure should always be set by increasing the pressure up to the desired setting.

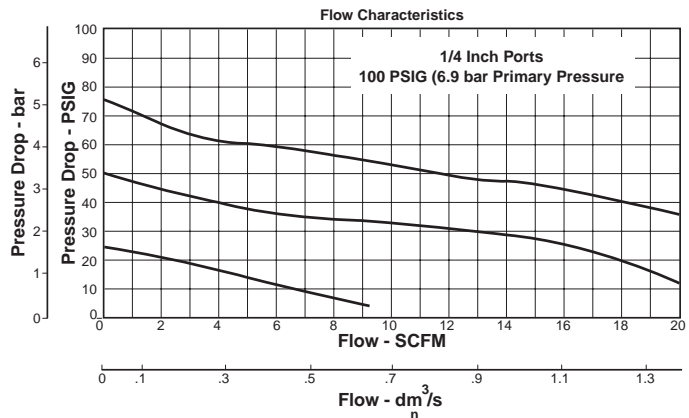

FR364 Regulator Kits & Accessories

R364 Bonnet Kit (Knob Included)	CKR364YSS
Gauge -	
160 PSIG (0 to 1100 kPa)	K4515N14160SS
Panel Mount Bracket (Stainless)	161X57-SS
Panel Mount Nut -	
Stainless	R05X51-SS
Plastic	R05X51-P
Service Kit -	
Relieving	RKR364YSS
Springs -	
0-125 PSIG Range	SPR-377-1-SS

Specifications

Gauge Port	1/4 Inch
Operation	Fluorocarbon Diaphragm
Port Threads	1/4 Inch
Pressure & Temperature Ratings -	300 PSIG Max (20.7 bar)
	40°F to 150°F [4°C to 66°C]
Weight	0.5 lb. (0.23 kg)

Materials of Construction

Adjustment Mechanism / Springs	316 Stainless Steel
Adjusting Knob (R364)	Polypropylene
Body	316 Stainless Steel
Bonnet (R364)	Acetal
Bottom Plug	316 Stainless Steel
Poppet	316 Stainless Steel
Seals	Fluorocarbon

Compressed Air Filters

Air Preparation Units - 05R Regulators - Economy

1/4", 3/8" NPT - Basic 1/4" Body

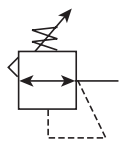

Features

- Secondary aspiration plus balanced poppet provides quick response and accurate pressure regulation.
- Rolling diaphragm for extended life.
- Removable non-rising knob for panel mounting and tamper resistance.
- Easily serviced.
- Reverse Flow.
- High Flow: 1/4" - 30 SCFM [51 Nm³/hr][§]
3/8" - 40 SCFM [68 Nm³/hr][§]

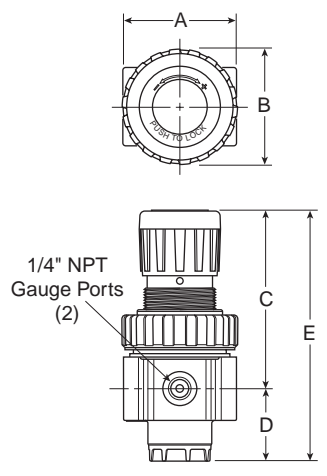

Port Size	NPT
Without Gauge	
1/4"	05R113A*
3/8"	05R213A*
With 160 PSI Gauge	
1/4"	05R118A*
3/8"	05R218A*

05R Regulator Dimensions		
A	B	C
2.00 (51)	2.06 (52)	3.16 (80)
D	E	
1.28 (32)	4.44 (113)	

Inches (mm)

NOTE: 1.53 Dia. (39mm) hole required for panel mounting.

[§] SCFM = Standard cubic feet per minute.
Nm³/hr = Normal cubic meters per hour.

Ordering Information

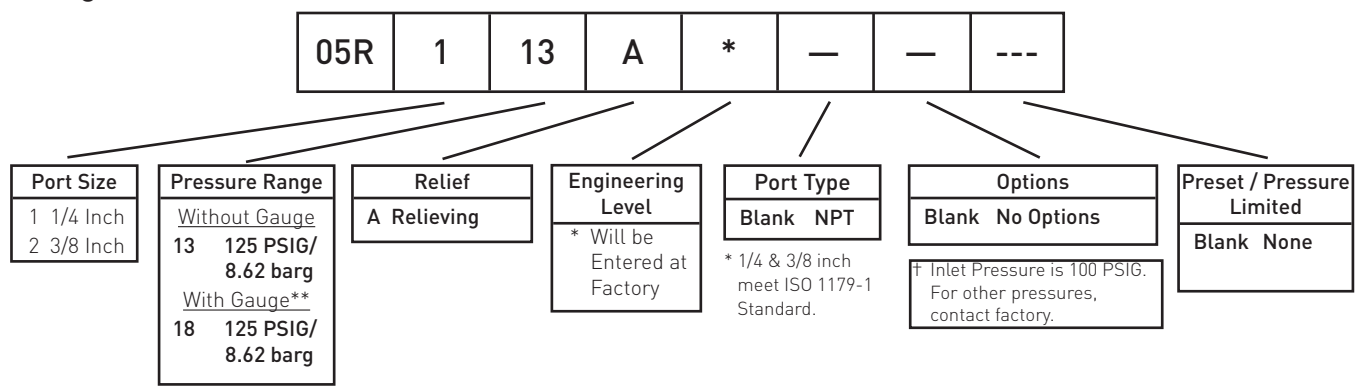

** Includes 1-1/2" Dial Face Gauge

Compressed Air Filters

Air Preparation Units 05R Air Line Regulators Technical Information

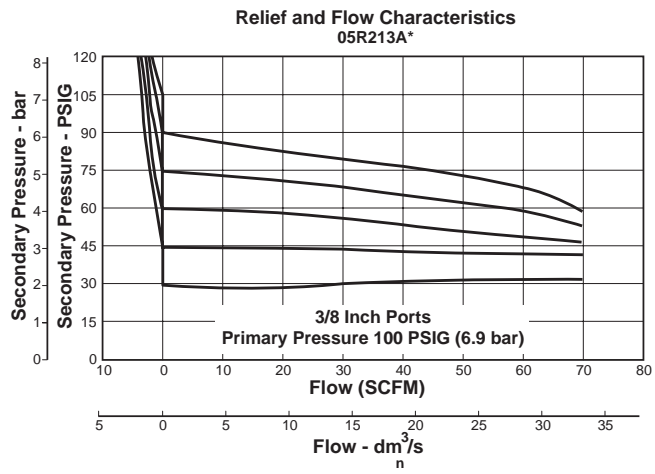
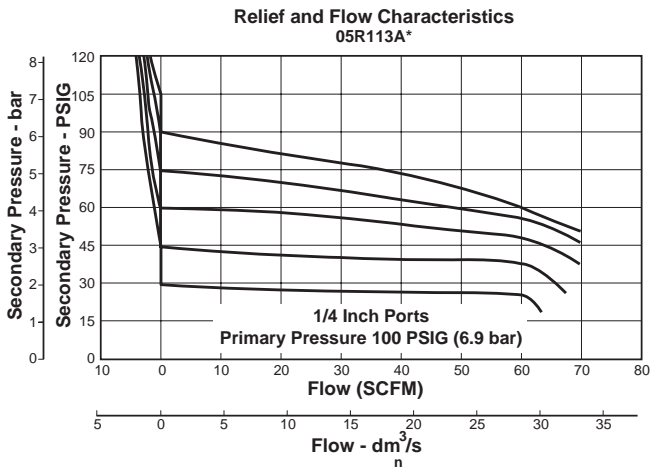

CAUTION:

REGULATOR PRESSURE ADJUSTMENT – The working range of knob adjustment is designed to permit outlet pressures within their full range. Pressure adjustment beyond this range is also possible because the knob is not a limiting device. This is a common characteristic of most industrial regulators, and limiting devices may be obtained only by special design.

For best performance, regulated pressure should always be set by increasing the pressure up to the desired setting.

⚠ WARNING

Product rupture can cause serious injury.
Do not connect regulator to bottled gas.
Do not exceed maximum primary pressure rating.

05R Regulator Kits & Accessories

Bonnet Assembly Kit	PS915P
Control Knob	P04420
Gauges – 1-1/2" Dial Face ????	
30 PSIG [0 to 2.1 bar]	K4515N14030
60 PSIG [0 to 4.1 bar]	K4515N14060
160 PSIG [0 to 11.0 bar]	K4515N14160
300 PSIG [0 to 20.0 bar]	K4515N14300
2" Dial Face	
60 PSIG [0 to 4.1 bar]	K4520N14060
160 PSIG [0 to 11.0 bar]	K4520N14160

Mounting Bracket Kit	PS963P
Panel Mount Nut – Metal	PS964P
Springs – 1-30 PSIG Range	P04427
1-60 PSIG Range	P04426
2-125 PSIG Range	P04425
2-200 PSIG	P02934
Service Kit – Relieving	PS908P

Specifications

Gauge Ports (2)	1/4 Inch
Port Threads	1/4, 3/8 Inch
Primary Pressure Rating –	
Maximum Primary Pressure	250 PSIG (17.2 bar) Max.
For Secondary Pressure Ranges see above charts.	
Temperature Rating	32°F to 175°F [0°C to 80°C]
Low Temperature	-4°F to 125°F [-20°C to 52°C]
Weight	1.1 lb. (0.49 kg)

Materials of Construction

Adjusting Stem	Brass
Bonnet	Plastic
Body	Zinc
Collar, Knob	Plastic
Diaphragm	Nitrile
Poppet & Cap	Plastic
Seals	Nitrile
Springs – Poppet & Control	Steel

Compressed Air Filters

Air Preparation Units - FR10 Regulator - Standard 1/2" Ports

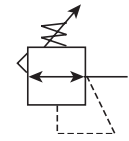

R10

Features

- Stainless steel construction handles most corrosive environments.
- Large diaphragm to valve area ratio for precise regulation and high flow capacity.
- Meets NACE specifications MR-01-75/ISO 15156.
- Low temperature version available.
- High Flow: 1/2" – 80 SCFM (136 Nm³/hr)[§]

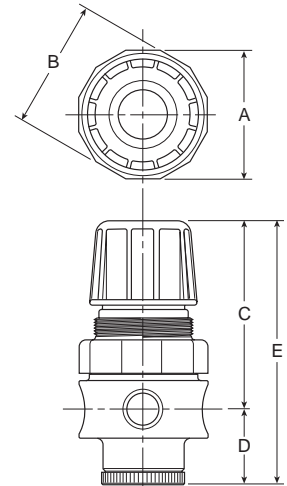

R10

Port Size	NPT
1/2"	FR10-04CSS

[§] SCFM = Standard cubic feet per minute.
Nm³/hr = Normal cubic meters per hour.

R10, R11 Regulator Dimensions		
A	B	C
2.34 (60)	2.43 (62)	3.59 (91)
D	E	
1.38 (35)	4.97 (126)	

inches (mm)
NOTE: 1.75 Dia. (44mm) hole required for panel mounting.

WARNING

Product rupture can cause serious injury.
Do not connect regulator to bottled gas.
Do not exceed maximum primary pressure rating.

Ordering Information

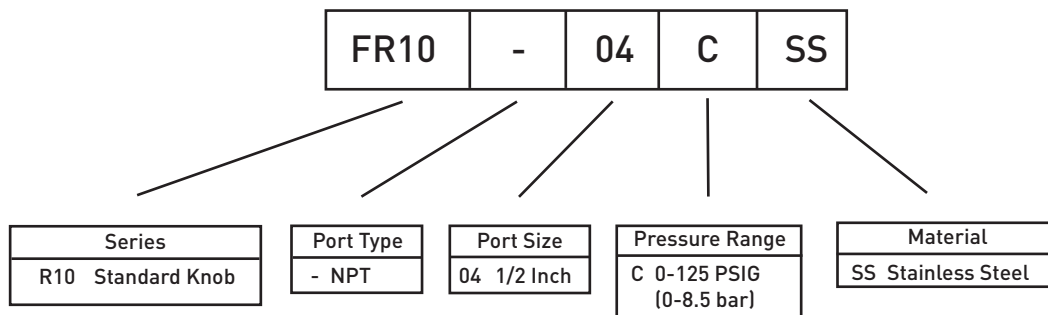

Compressed Air Filters

Air Preparation Units FR10 Air Line Regulators

Technical Information

Operation

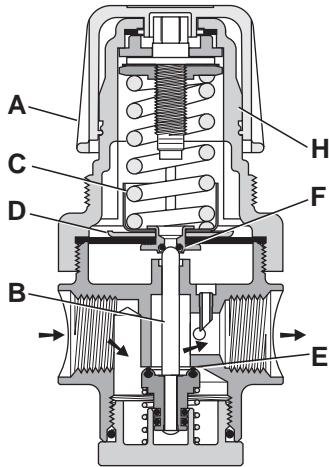

With the adjusting knob (A) turned fully counter-clockwise (no spring load), and pressure supplied to the regulator inlet port, the valve poppet assembly (B) is closed. Turning the adjusting knob clockwise applies a load to control spring (C). This load causes the diaphragm (D) and the valve poppet assembly (B) to move downward allowing flow across the seat area (E) created between the poppet assembly and the seat. Pressure in the downstream line is sensed below the diaphragm (D) and offsets the load of spring (C). As downstream pressure rises, poppet assembly (B) and diaphragm (D) move upward until the area (E) is closed and the load of the spring (C) and pressure under diaphragm (D) are in balance. A reduced outlet pressure has now been obtained, depending on spring load. Creating a demand downstream, such as opening a valve, results in a reduced pressure under the diaphragm (D). The load of control spring (C) now causes the poppet assembly to move downward opening seat area (E) allowing air to flow to meet the downstream demand. The flow of downstream air is metered by the amount of opening (E).

Should downstream pressure exceed the desired regulated pressure, the excess pressure will cause the diaphragm (D) to move upward against control spring (C), open vent hole (F), and vent the excess pressure to atmosphere through the hole in the bonnet (H). (This occurs in the relieving type regulator only.)

Technical Information

CAUTION:

REGULATOR PRESSURE ADJUSTMENT -

The working range of knob adjustment is designed to permit outlet pressures within their full range. Pressure adjustment beyond this range is also possible because the knob is not a limiting device. This is a common characteristic of most industrial regulators, and limiting devices may be obtained only by special design.

For best performance, regulated pressure should always be set by increasing the pressure up to the desired setting.

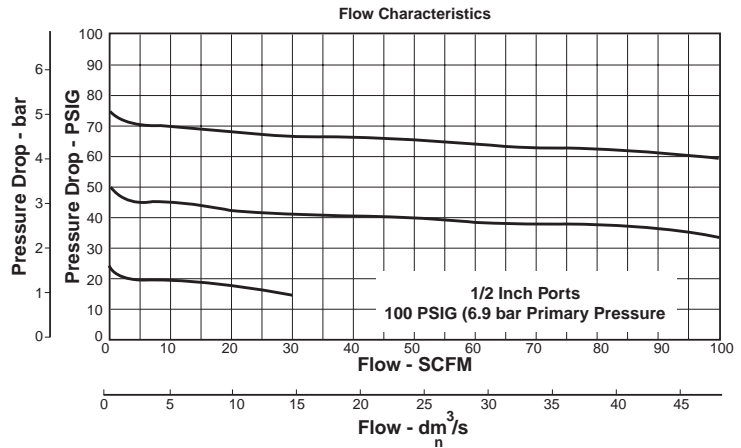

FR10 Regulator Kits & Accessories

R10 Bonnet Kit (Knob Included)	CKR10YSS
Gauge -	
160 PSIG (0 to 1100 kPa), 2" Face	K4520N14160SS
Panel Mount Bracket (Stainless)	161X57-SS
Panel Mount Nut -	
Stainless	R10X51-SS
Plastic	R10X51-P
Service Kit -	
Relieving	RKR10YSS
Springs -	
0-125 PSIG Range	SPR-389-1-SS

Specifications

Gauge Port	1/4 Inch
Operation	Fluorocarbon Diaphragm
Port Threads	1/2 Inch
Pressure & Temperature Ratings -	300 PSIG Max (20.7 bar)
	0°F to 150°F (-18°C to 66°C)

Note: Air must be dry enough to avoid ice formation at temperatures below 32°F (2°C).

Weight

Materials of Construction

Adjustment Mechanism / Springs	316 Stainless Steel
Body	316 Stainless Steel
Bonnet / Knob (R10)	Acetal
Bottom Plug	316 Stainless Steel
Poppet	316 Stainless Steel
Seals	Fluorocarbon

Compressed Air Filters

Air Preparation Units - 07R Regulators - Standard 3/8", 1/2", 3/4" NPT - Basic 1/2" Body

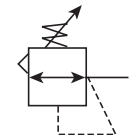

Features

- Secondary aspiration plus balanced poppet provides quick response and accurate pressure regulation.
- Rolling diaphragm for extended life.
- Two high flow 1/4" gauge ports can be used as additional outlets.
- Easily serviced.
- Removable non-rising knob for panel mounting and tamper resistance.
- High Flow: 3/8" - 70 SCFM (119 Nm³/hr) §
1/2" - 90 SCFM (153 Nm³/hr) §
3/4" - 90 SCFM (153 Nm³/hr) §

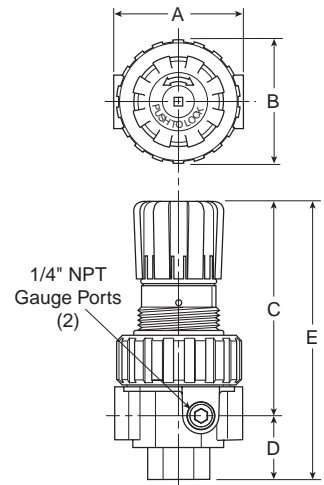

Port Size	NPT
Without Gauge	
3/8"	07R213A*
1/2"	07R313A*
3/4"	07R413A*

07R Regulator Dimensions		
A	B	C
3.24 (82)	2.74 (70)	4.79 (122)
D	E	
1.61 (41)	6.40 (163)	

Inches (mm)

NOTE: 2.00 Dia. (51mm) hole required for panel mounting.

§ SCFM = Standard cubic feet per minute.
Nm³/hr = Normal cubic meters per hour.

⚠ WARNING

Product rupture can cause serious injury.
Do not connect regulator to bottled gas.
Do not exceed maximum primary pressure rating.

Ordering Information

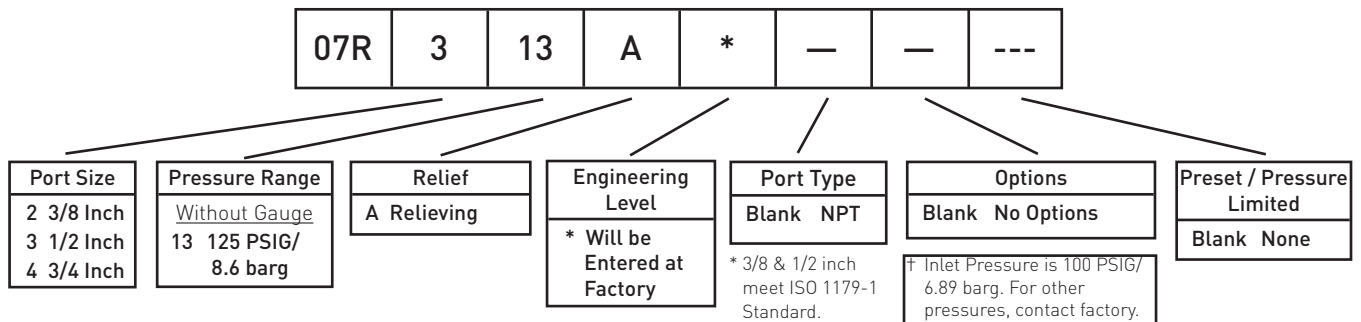

Compressed Air Filters

Air Preparation Units 07R Air Line Regulators Technical Information

Compressed Air Filters

Relief And Flow Characteristics
07R213A*

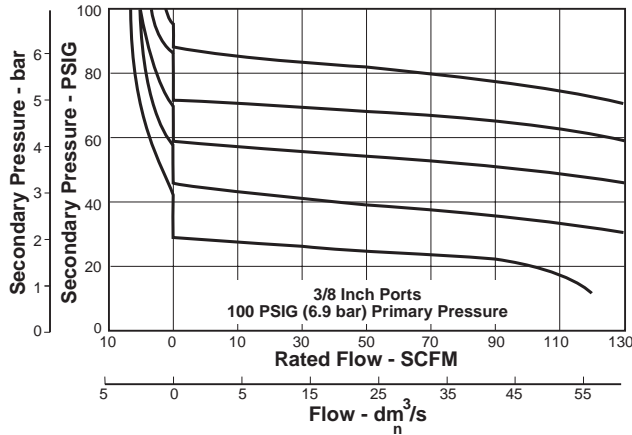

Relief And Flow Characteristics
07R313A*

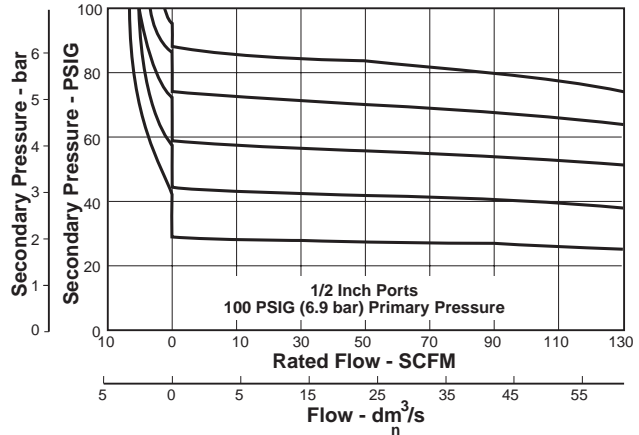

Relief And Flow Characteristics
07R413A*

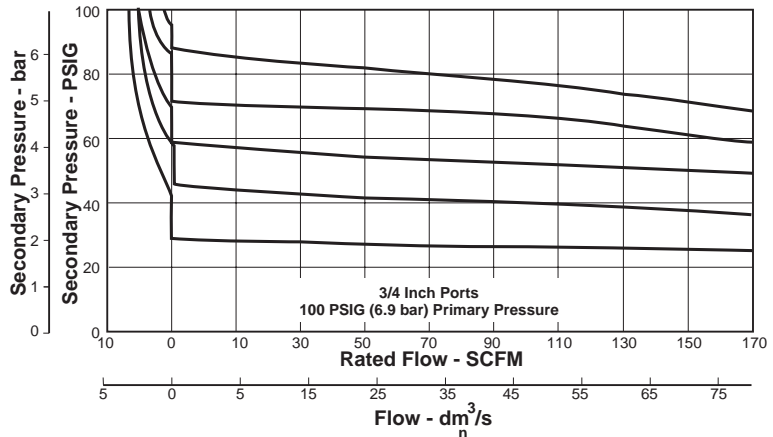

CAUTION:

REGULATOR PRESSURE ADJUSTMENT -

The working range of knob adjustment is designed to permit outlet pressures within their full range. Pressure adjustment beyond this range is also possible because the knob is not a limiting device. This is a common characteristic of most industrial regulators, and limiting devices may be obtained only by special design.

For best performance, regulated pressure should always be set by increasing the pressure up to the desired setting.

07R Regulator Kits & Accessories

Bonnet Assembly Kit	PS715P
Control Knob	P04069B
Gauges - 60 PSIG (0 to 4.1 bar)	K4520N14060
160 PSIG (0 to 11.0 bar)	K4520N14160
Mounting Bracket Kit (Includes Panel Mount Nut)	PS807P
Panel Mount Nut - Plastic	P04082
Metal	P04079B
Service Kit - Relieving (Includes Poppet)	PS808P
Springs - 2-125 PSIG Range	P04063
Tamperproof Kit	PS737P

Specifications

Gauge Ports (2)	1/4 Inch
(Can be used as additional High Flow 1/4 Inch Outlet Ports)	
Port Threads	3/8, 1/2, 3/4 Inch
Primary Pressure Rating -	
Maximum Primary Pressure	250 PSIG (17.2 bar)
Secondary Pressure Range -	
Standard Pressure	2 to 125 PSIG (0 to 8.6 bar)
Temperature Rating	32°F to 175°F (0°C to 80°C)
Weight 2.5 lb. (1.1 kg)	

Materials of Construction

Adjusting Stem	Steel
Body	Zinc
Bonnet, Piston Stem, Valve Poppet & Cap	Plastic
Collar, Knob	Plastic
Diaphragm	Nitrile
Seals	Nitrile
Springs - Poppet	Stainless
Control	Steel

Compressed Air Filters

Air Preparation Units - P3NR Regulators - High Flow 3/4", 1", 1 1/2" NPT - Basic 1" Body

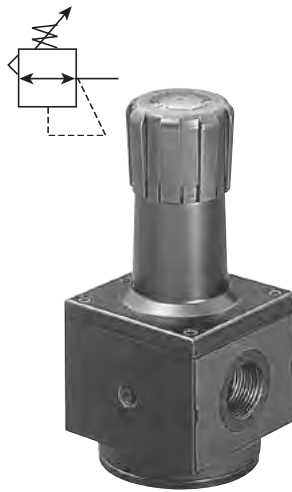

Features

- Port blocks (PB) available to provide 1-1/2" port extension to 1" ported bodies.
- Self relieving feature plus balanced poppet provides quick response and accurate pressure regulation.
- Solid control piston for extended life.
- High Flow: 3/4" - 200 SCFM (340 Nm³/hr) §
1" - 300 SCFM (510 Nm³/hr) §
1 1/2" - 300 SCFM (510 Nm³/hr) §

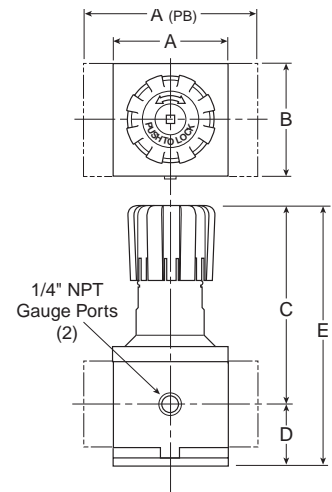

Port Size	NPT
Without Gauge	
3/4"	P3NRA96BNN
1"	P3NRA98BNN
1 1/2"	P3NRA9PBNN

P3NR Regulator Dimensions		
A	A ^(PB)	B
3.62 (92)	5.91 (150)	3.62 (92)
C	D	E
6.38 (162)	2.08 (53)	8.46 (215)

Inches (mm)

NOTE: 2.00 Dia. (51mm) hole required for panel mounting.

§ SCFM = Standard cubic feet per minute.
Nm³/hr = Normal cubic meters per hour.

	WARNING
<p>Product rupture can cause serious injury. Do not connect regulator to bottled gas. Do not exceed maximum primary pressure rating.</p>	

Ordering Information

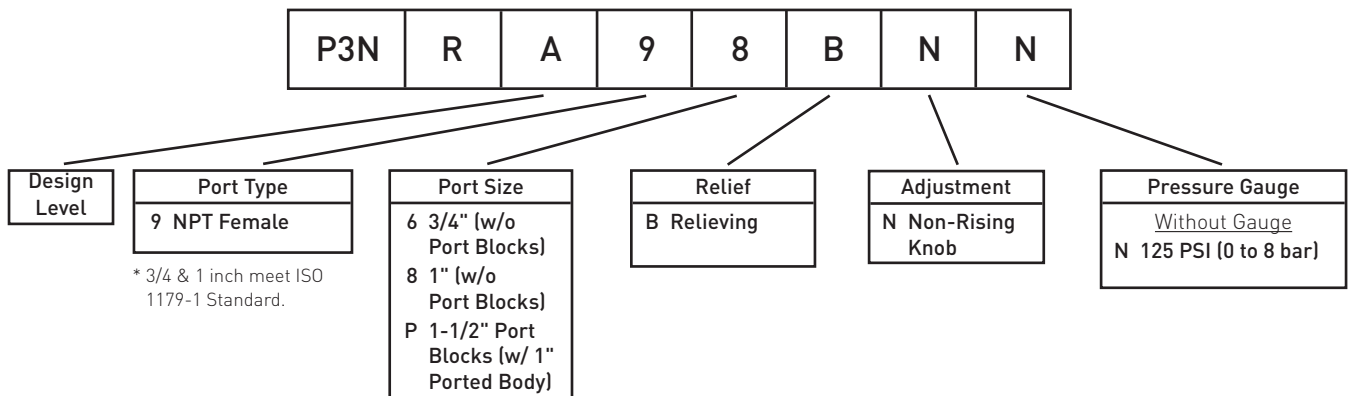

Compressed Air Filters

Air Preparation Units - P3NR Air Line Regulators

Technical Information

Compressed Air Filters

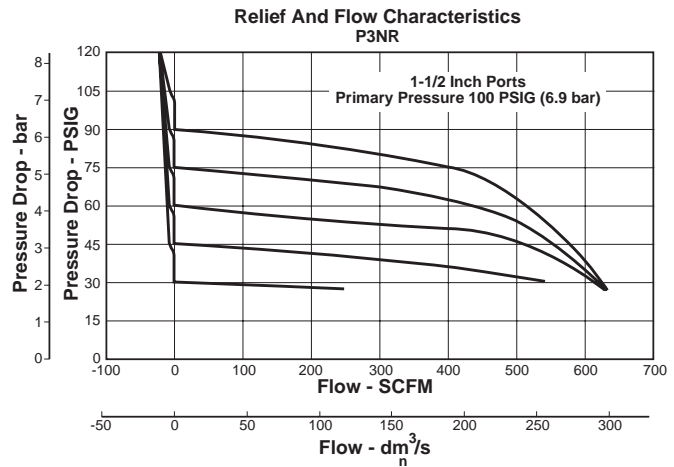
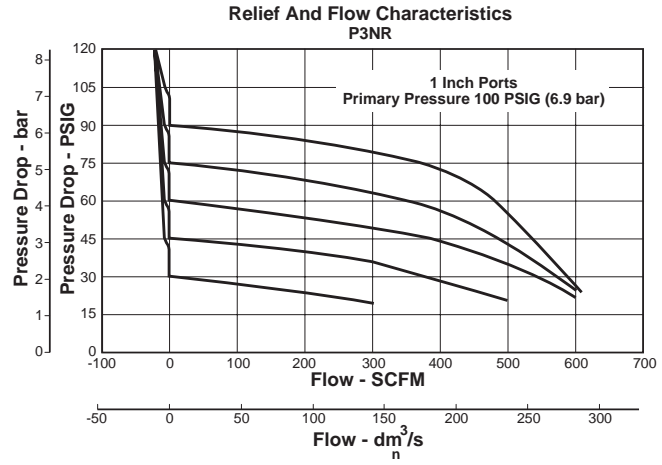
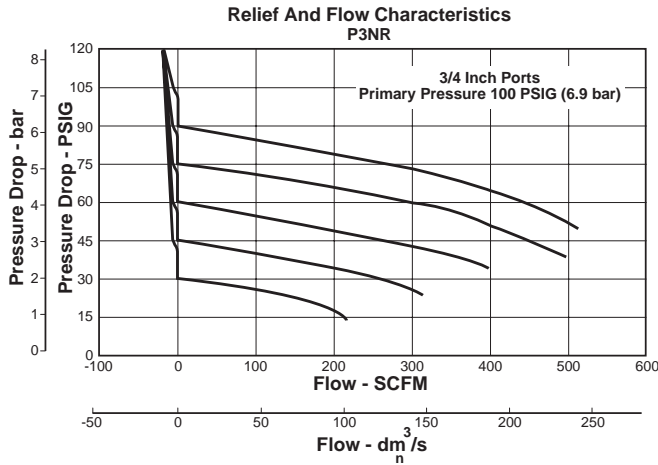

CAUTION:

REGULATOR PRESSURE ADJUSTMENT –

The working range of knob adjustment is designed to permit outlet pressures within their full range. Pressure adjustment beyond this range is also possible because the knob is not a limiting device. This is a common characteristic of most industrial regulators, and limiting devices may be obtained only by special design.

For best performance, regulated pressure should always be set by increasing the pressure up to the desired setting.

P3NR Regulator Kits & Accessories

- Control Knob P3NKA00PN
- Gauges – 60 PSIG (0 to 4.1 bar) K4520N14060
- 160 PSIG (0 to 11.0 bar) K4520N14160
- Mounting Bracket Kit* P3NKA00MW
- Service Kit – Relieving P3NKA00RR
- Springs – 2-125 PSIG Range C10A1308

Specifications

- Gauge Ports (2) 1/4 Inch
(Can be used as additional High Flow 1/4 Inch Outlet Ports)
- Port Threads 3/4, 1, 1-1/2 Inch
- Primary Pressure Rating –
Maximum Primary Pressure 250 PSIG (17.2 bar)
- Secondary Pressure Range –
Standard Pressure 2 to 125 PSIG (0 to 8.6 bar)
- Temperature Rating 32°F to 175°F (0°C to 80°C)

- Weight – 3/4" 4.2 lb. (1.9 kg)
- 1" 4.2 lb. (1.9 kg)
- 1½" † 5.3 lb. (2.4 kg)

Materials of Construction

- Adjusting Stem Steel
- Body Aluminum
- Bonnet Aluminum
- Knob Plastic
- Piston Plastic
- Poppet Assembly Brass
- Seals Nitrile
- Springs – Poppet & Control Steel

† 1" Port Body with 1½" Port Block.



Compressed Air Filters

Air Preparation Units - 14E Filter/Regulator - Miniature 1/8", 1/4" NPT - Basic 1/8" Body

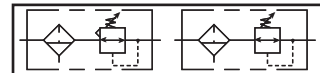

Features

- Excellent water removal efficiency.
- Unbalanced poppet standard.
- Solid control piston for extended life.
- Space saving package offers both filter and regulator features in one integral unit.
- Non-rising adjustment knob.
- Two full flow 1/8" gauge ports.
- High Flow: 1/8" - 16 SCFM (27 Nm³/hr) §
1/4" - 18 SCFM (31 Nm³/hr) §

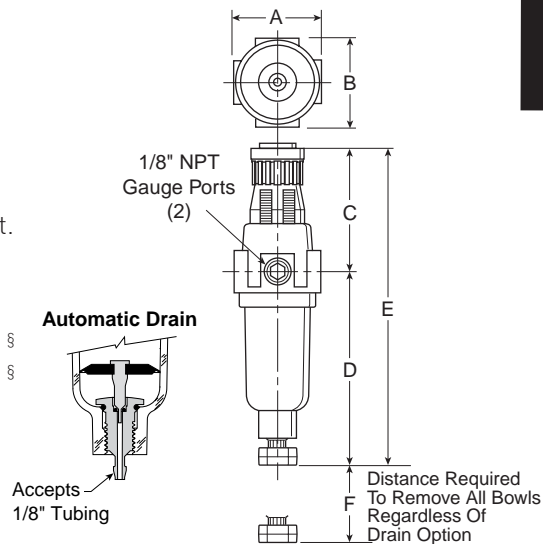

Port Size	NPT	
	Twist Drain	Automatic Pulse Drain
Poly Bowl [‡]		
1/8"	14E01B13F*	14E05B13F*
1/4"	14E11B13F*	14E15B13F*
Metal Bowl		
1/8"	14E03B13F*	14E07B13F*
1/4"	14E13B13F*	14E17B13F*

[‡] For polycarbonate bowl see Caution on page A2.

§ SCFM = Standard cubic feet per minute.
Nm³/hr = Normal cubic meters per hour.

A	B	C
1.62 (41)	1.58 (40)	2.42 (61)
D	D [†]	E
3.79 (96)	3.64 (92)	6.21 (158)
E [†]	F	
6.06 (154)	1.60 (41)	

Inches (mm)
[†] With Auto Drain

NOTE: 1.218 Dia. [31mm] hole required for panel mounting.

Ordering Information

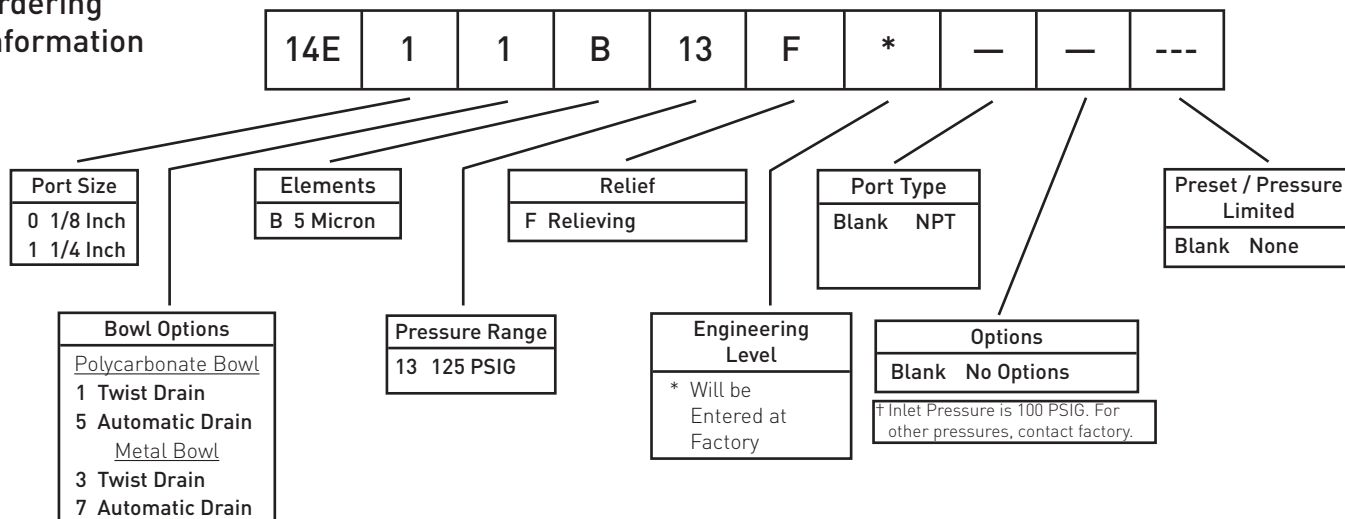

Compressed Air Filters

Air Preparation Units - Prep Air II, 14E Filter/Regulators Technical Information

Compressed Air Filters

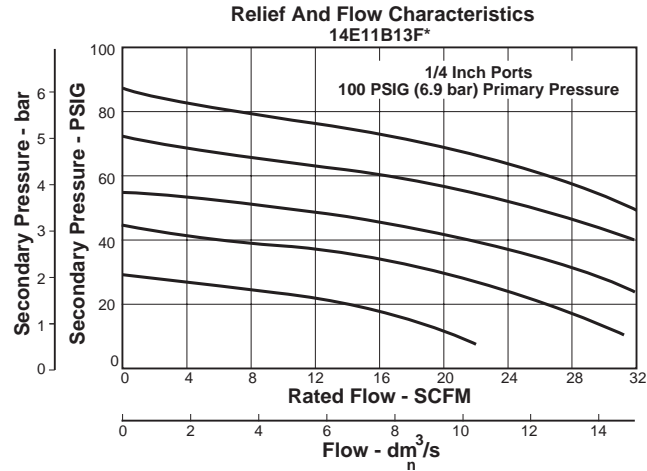
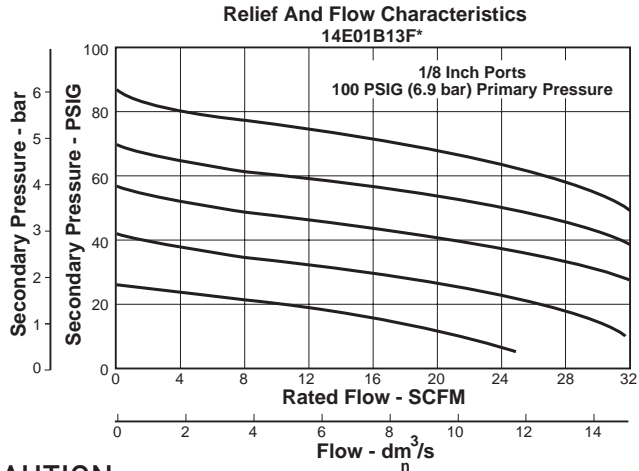

CAUTION:

REGULATOR PRESSURE ADJUSTMENT – The working range of knob adjustment is designed to permit outlet pressures within their full range. Pressure adjustment beyond this range is also possible because the knob is not a limiting device. This is a common characteristic of most industrial regulators, and limiting devices may be obtained only by special design.

For best performance, regulated pressure should always be set by increasing the pressure up to the desired setting.

14E Filter / Regulator Kits & Accessories

Bowl Kits –	
Poly Bowl – Automatic Drain	PS408BP
Twist Drain.....	PS404P
Metal Bowl – Automatic Drain	PS451BP
Twist Drain.....	PS447BP
Filter Element Kits – 5 Micron.....	
PS403P	
Gauges –????	
30 PSIG (0 to 2.1 bar).....	K4515N18030
60 PSIG (0 to 4.1 bar).....	K4515N18060
160 PSIG (0 to 11.0 bar).....	K4515N18160
Mounting Bracket Kit (Includes Panel Mount Nut)	
PS417BP	
Panel Mount Nut	
P78652	
Poppet Kit – Unbalanced.....	
PS424BP	

Service Kit – Relieving	PS423P
Springs – 2- 125 PSIG Range (Gold).....	P01173

Specifications

Automatic Pulse Drain Tube Barb	1/8 Inch
Bowl Capacity	1 Ounce
Gauge Ports (2) (Can be used for Full Flow).....	1/8 Inch
Port Threads	1/8, 1/4 Inch

Pressure & Temperature Ratings –

- Polycarbonate Bowl
 - 0 to 150 PSIG (0 to 10.3 bar), 32°F to 125°F (0°C to 52°C)
- Metal Bowl
 - 0 to 250 PSIG (0 to 17.2 bar), 32°F to 175°F (0°C to 80°C)

WARNING

Product rupture can cause serious injury.
Do not connect regulator to bottled gas.
Do not exceed maximum primary pressure rating.

Secondary Pressure Ranges –

Standard Pressure..... 2 to 125 PSIG (0 to 8.6 bar)

Weight..... 0.4 lb. (0.18 kg)

Materials of Construction

Adjusting Nut	Brass
Adjusting Stem & Spring	Steel
Body	Zinc
Bonnet, Knob, Seat, Piston, Holder & Deflector	Plastic
Bowls Available –	
Transparent	Polycarbonate
Metal (Without Sight Gauge)	Zinc
Drains – Manual – Twist Type	
Body & Stem	Plastic
Seals.....	Nitrile
Automatic – Pulse Type	
Piston & Seals	Nitrile
Stem, Seat, Adaptor & Washers	Aluminum
Filter Elements – 5 Micron (Standard).....	
Plastic	
Seals	
Nitrile	

Compressed Air Filters

Air Preparation Units - FB548 Filter/Regulator - Miniature 1/4" Ports

Compressed Air Filters

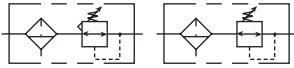

B548

Features

- Stainless Steel Construction Handles Most Corrosive Environments
- Large Diaphragm To Valve Area Ratio For Precise Regulation And High Flow Capacity
- 1/8" Female Threaded Drain*
- Meets NACE Specifications MR-01-75/ISO 15156.
- High Flow: 1/4" - 12 SCFM (20 Nm³/hr) §

* Beginning January 2008

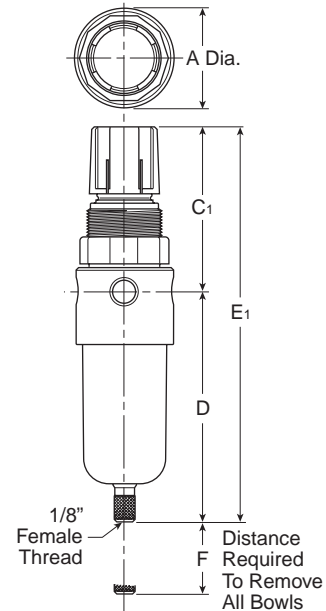

Port Size	NPT
1/4"	FB548-02DGCSS

FB548 Piggyback Dimensions		
A	C ₁	D
1.56 (40)	2.17 (55)	3.63 (92)
E ₁	F	
3.06 (78)	1.58 (40)	

§ SCFM = Standard cubic feet per minute.
Nm³/hr = Normal cubic meters per hour.

inches (mm)
NOTE: 1.25 Dia. (32mm) hole required for panel mounting.

WARNING
<p>Product rupture can cause serious injury. Do not connect regulator to bottled gas. Do not exceed maximum primary pressure rating.</p>

Ordering Information

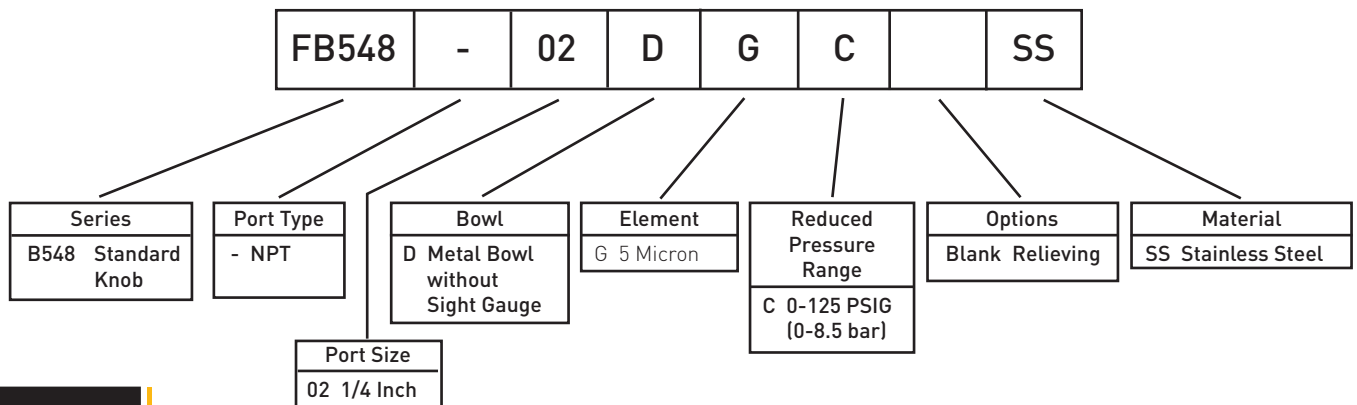

Compressed Air Filters

Air Preparation Units - FB548 Filter/Regulators Technical Information

Compressed Air Filters

Operation

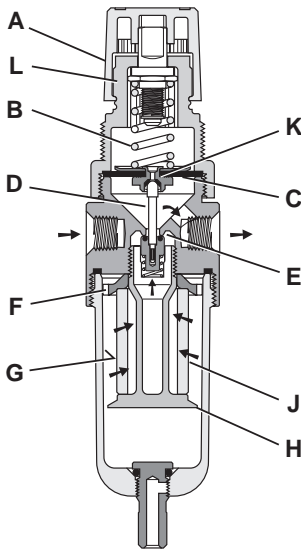

Turning the adjusting knob clockwise applies a load to control spring (B) which forces diaphragm (C) and valve poppet assembly (D) to move downward allowing filtered air to flow through the seat area (E) created between the poppet assembly and the seat. "First stage filtration". Air pressure supplied to the inlet port is directed through deflector plate (F) causing a swirling centrifugal action forcing liquids and coarse particles to the inner bowl wall (G) and down below the lower baffle (H) to the quiet zone. After liquids and large particles are removed in the first stage of filtration "second stage filtration" occurs as air flows through element (J) where smaller particles are filtered out and retained. The air flow now passes through seat area (E) to the outlet port of the unit. Pressure in the downstream line is sensed below the diaphragm (C) and offsets the load of spring (B). When downstream pressure reaches the set-point, poppet valve assembly (D) and diaphragm (C) move upward closing seat area (E). Should downstream pressure exceed the desired regulated pressure, the excess pressure will cause the diaphragm (C) to move upward opening vent hole (K) venting the excess pressure to atmosphere through the hole in the bonnet (L). (This occurs in the standard relieving type filter/regulators only.)

Technical Information

CAUTION:

REGULATOR PRESSURE ADJUSTMENT – The working range of knob adjustment is designed to permit outlet pressures within their full range. Pressure adjustment beyond this range is also possible because the knob is not a limiting device. This is a common characteristic of most industrial regulators, and limiting devices may be obtained only by special design.

For best performance, regulated pressure should always be set by increasing the pressure up to the desired setting.

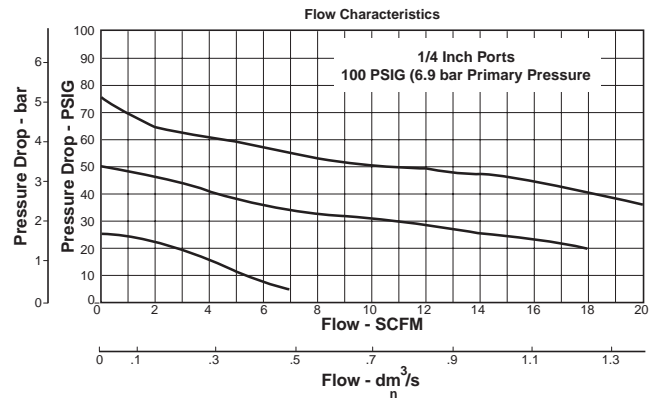

FB548, Regulator Kits & Accessories

FB548 Bonnet Kit (Knob Included)	CKR364YSS
Filter Element Kits -	
Particulate (5 Micron).....	EK504VY
Gauge -	
160 PSIG (0 to 1100 kPa), 2" Face.....	K4515N14160SS
Manual Twist Drain	SA600Y7-1SS
Panel Mount Bracket (Stainless).....	161X57-SS
Panel Mount Nut -	
Stainless	R05X51-SS
Plastic	R05X51-P
Service Kit -	
Relieving	RK549YSS
Springs -	
0-125 PSIG Range	SPR-377-1-SS

Specifications

Bowl Capacity	1.0 Ounces/28 ml
Filter Rating	5 Micron
Gauge Port	1/4 Inch
Operation	Fluorocarbon Diaphragm
Port Threads	1/4 Inch
Pressure & Temperature Ratings -	300 PSIG Max (20.7 bar) 0°F to 150°F (-18°C to 66°C)
Note: Air must be dry enough to avoid ice formation at temperatures below 32°F (2°C).	
Sump Capacity	0.4 Ounce (11 ml)
Weight	0.6 lb. (0.27 kg)

Materials of Construction

Adjustment Mechanism / Springs	316 Stainless Steel
Body	316 Stainless Steel
Bonnet (B548)	Acetal
Bottom Plug	316 Stainless Steel
Knob (B548)	Polypropylene
Poppet	316 Stainless Steel
Seals	Fluorocarbon



Compressed Air Filters

Air Preparation Units - 06E Filter/Regulator - Compact 1/4", 3/8", 1/2" NPT - Basic 3/8" Body

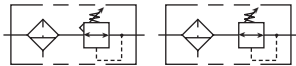

Features

- Space saving package offers both filter and regulator features for optimal performance.
- Excellent water removal efficiency.
- Rolling diaphragm for extended life.
- Quick response, and accurate pressure regulation regardless of changing flow or inlet pressure.
- Two high flow 1/4" gauge ports can be used as additional outlets.
- Shown with recommended metal bowl guard.
- High Flow: 1/4" – 46 SCFM (78 Nm³/hr) §
3/8" – 55 SCFM (93 Nm³/hr) §
1/2" – 61 SCFM (104 Nm³/hr) §

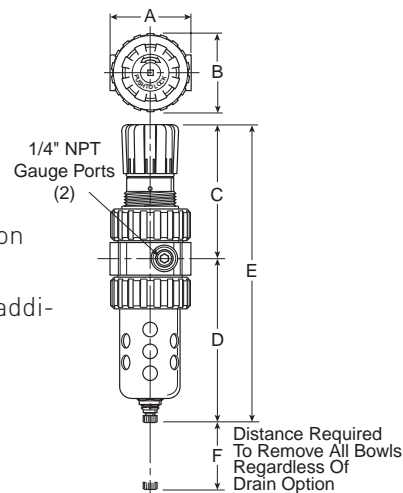

Port Size	NPT	
	Twist Drain	Automatic Float Drain
Poly Bowl [‡] / Metal Guard		
1/4"	06E12B13A*	06E16B13A*
3/8"	06E22B13A*	06E26B13A*
1/2"	06E32B13A*	06E36B13A*
Metal Bowl / Sight Gauge		
1/4"	06E14B13A*	06E18B13A*
3/8"	06E24B13A*	06E28B13A*
1/2"	06E34B13A*	06E38B13A*

06E Filter / Regulator Dimensions			
A	B	C	D
2.81 (71)	2.74 (70)	4.69 (119)	5.69 (145)
D [†]	E	E [†]	F
5.74 (146)	10.38 (264)	10.43 (265)	2.25 (57)

Inches (mm)
[†] With Twist Drain or Auto Pulse Drain

[‡] For polycarbonate bowl see Caution on page 2.

[§] SCFM = Standard cubic feet per minute.
 Nm³/hr = Normal cubic meters per hour.

NOTE: 2.00 Dia. (50.8 mm) hole required for panel mounting. Max. panel thickness 1/4".

⚠ WARNING

Product rupture can cause serious injury.
 Do not connect regulator to bottled gas.
 Do not exceed maximum primary pressure rating.

Ordering Information

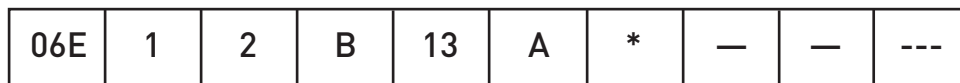

Port Size

1 1/4 Inch
 2 3/8 Inch
 3 1/2 Inch

Elements

B 5 Micron

Relief

A Relieving

Port Type

Blank NPT

* 1/4 & 3/8 inch meet ISO 1179-1 Standard.

Preset

Blank None

Bowl Options

Polycarbonate Bowl	Metal Bowl
2 Metal Bowl Guard / Twist Drain	4 Sight Gauge / Twist Drain
6 Metal Bowl Guard / Auto Float Drain	8 Sight Gauge / Auto Float Drain

Pressure Range

13 125 PSIG

Engineering Level

* Will be Entered at Factory

Options

Blank No Options

† Inlet Pressure is 100 PSIG. For other pressures, contact factory.

Compressed Air Filters

Air Preparation Units - 06E Filter/Regulators Technical Information

Compressed Air Filters

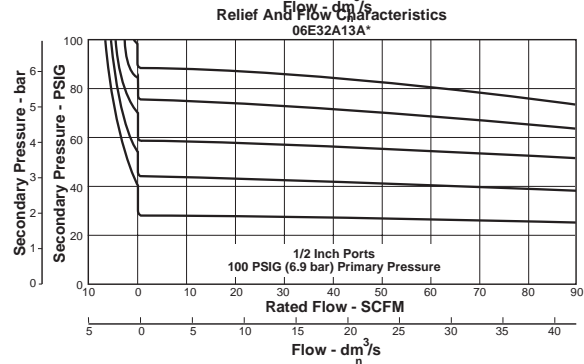
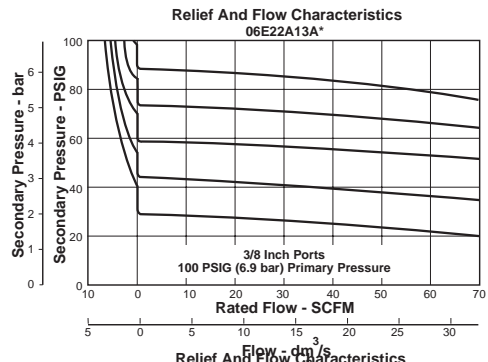
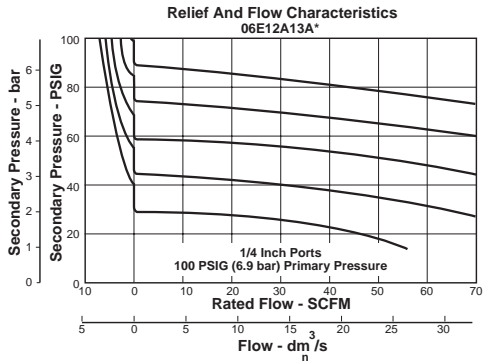

CAUTION:

REGULATOR PRESSURE ADJUSTMENT – The working range of knob adjustment is designed to permit outlet pressures within their full range. Pressure adjustment beyond this range is also possible because the knob is not a limiting device. This is a common characteristic of most industrial regulators, and limiting devices may be obtained only by special design.

For best performance, regulated pressure should always be set by increasing the pressure up to the desired setting.

06E Filter / Regulator Kits & Accessories

Bonnet Assembly Kit.....	PS715P
Bowl Guard Kit	PS705P
Bowl Kits –	
Poly Bowl – Automatic Float Drain	PS722P
Twist Drain	PS732P
Metal Bowl – Sight Gauge / Automatic Drain	PS723P
Sight Gauge / Twist Drain.....	PS735P
Control Knob.....	P04069B
Drain Kit – Automatic Float Drain	PS506P
Twist Drain.....	PS512P
Filter Element Kits – 5 Micron.....	PS702
Gauges – 60 PSIG (0 to 4.1 bar).....	K4520N14060
160 PSIG (0 to 11.0 bar).....	K4520N14160
Mounting Bracket Kit (Includes Panel Mount Nut).....	PS707P
Panel Mount Nut	P04082
Service Kits – Non-Relieving (Includes Poppet).....	PS711P
Relieving (Includes Poppet).....	PS710P
Seat Insert Kit	PS713P
Spring – 2- 125 PSIG Range.....	P04063
Tamperproof Kit (Key Lock)	PS737P

Specifications

Bowl Capacity	4.4 Ounces (125 ml)
Gauge Ports (2)	1/4 Inch (Can be used as Additional Full Flow 1/4" Outlet Ports)
Port Threads	1/4, 3/8, 1/2 Inch

Pressure & Temperature Ratings –

Polycarbonate Bowl – 0 to 150 PSIG (0 to 10.4 bar)
32°F to 125°F (0°C to 52°C)
Metal Bowl – 0 to 250 PSIG (0 to 17.2 bar)
32°F to 175°F (0°C to 80°C)
Automatic Float Drain – 15 to 250 PSIG (1.0 to 17.2 bar)

Secondary Pressure Range –

Standard Pressure.....	2 to 125 PSIG (0 to 8.6 bar)
------------------------	------------------------------

Sump Capacity.....	1.75 Ounces
Weight.....	1.6 lb. (0.7 kg)

Materials of Construction

Adjusting Stem	Steel
Body	Zinc
Bonnet, Internal Parts	Plastic
Bowls Available – Transparent	Polycarbonate
Metal (With or Without Sight Gauge)	Zinc
Bowl Guard	Steel
Collar	Plastic
Diaphragm.....	Nitrile
Drains – Manual Twist Drain Standard	
Body & Nut	Plastic
Automatic Float Drain Optional (Interchangeable for Field Conversions)	
Operating Range.....	10 to 250 PSIG (.7 to 17.2 bar)
Housing, Float	Plastic
Seals	Nitrile
Springs, Push Rod.....	Stainless Steel
Knob	Plastic
Filter Elements – 5 Micron (Optional).....	Plastic

Seals	Nitrile
Sight Gauge	Polyamide
Springs – Poppet	Stainless
Control.....	Steel



Compressed Air Filters

Air Preparation Units - FB11 Filter/Regulator - Standard 1/2" Ports

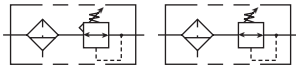

B11

Features

- Stainless steel construction handles most corrosive environments.
- Large diaphragm to valve area ratio for precise regulation and high flow capacity.
- 1/8" female threaded drain.
- Meets NACE specifications MR-01-75/ISO-15156.
- Low temperature version available.
- High Flow: 1/2" - 72 SCFM (122 Nm³/hr) §

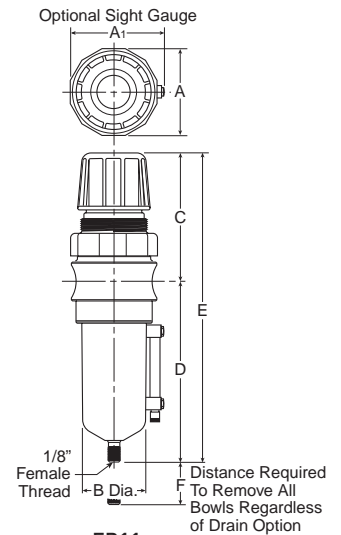

FB11

Port Size	Adjustment Type	NPT		BSPP	
		Manual Twist Drain	Automatic Float Drain	Manual Twist Drain	Automatic Float Drain
1/2"	Metal Bowl with Sight Gauge				
	Knob	FB11-04WGCSS	FB11-04WGRSS	FB11G04WGCSS	FB11G04WGRSS

FB11 Piggyback Dimensions		
A 2.34 (60)	A1 2.50 (64)	B 1.75 (44)
C 3.59 (91)	D 5.00 (127)	E 8.59 (218)
F 2.12 (54)		

Standard part numbers shown bold. For other models refer to ordering information below.

§ SCFM = Standard cubic feet per minute.
Nm³/hr = Normal cubic meters per hour.

⚠ WARNING

Product rupture can cause serious injury.
Do not connect regulator to bottled gas.
Do not exceed maximum primary pressure rating.

inches (mm)
NOTE: 1.75 Dia. (44mm) hole required for panel mounting.

Ordering Information

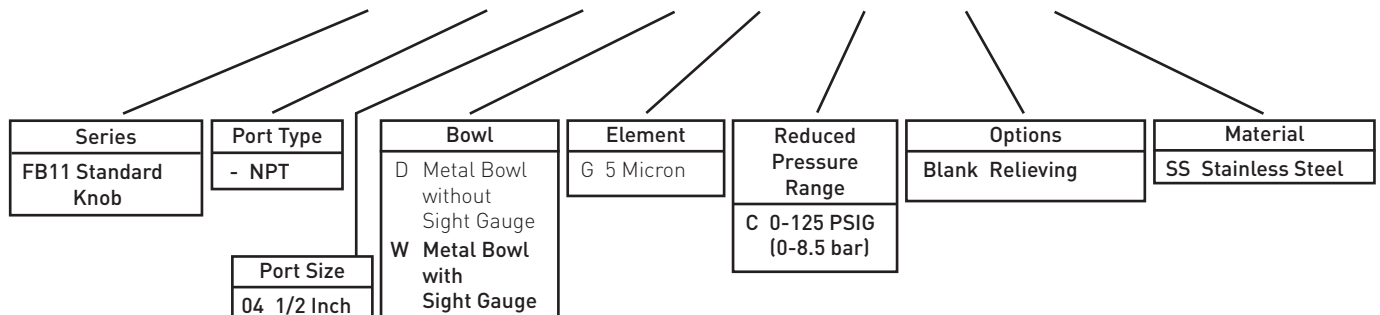
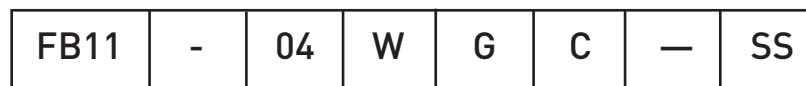

Compressed Air Filters

Air Preparation Units - FB11 Filter/Regulators Technical Information

Compressed Air Filters

Operation

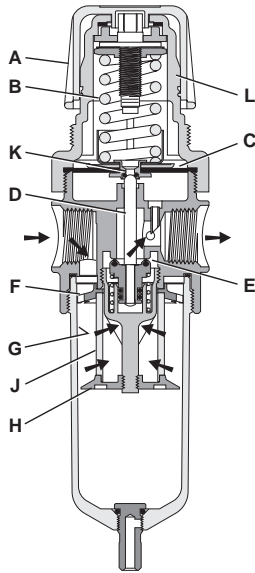

Turning the adjusting knob clockwise applies a load to control spring (B) which forces diaphragm (C) and valve poppet assembly (D) to move downward allowing filtered air to flow through the seat area (E) created between the poppet assembly and the seat. "First stage filtration".

Air pressure supplied to the inlet port is directed through deflector plate (F) causing a swirling centrifugal action forcing liquids and coarse particles to the inner bowl wall (G) and down below the lower baffle (H) to the quiet zone. After liquids and large particles are removed in the first stage of filtration "second stage filtration" occurs as air flows through element (J) where smaller particles are filtered out and retained. The air flow now passes through seat area (E) to the outlet port of the unit. Pressure in the downstream line is sensed below the diaphragm (C) and offsets the load of spring (B). When downstream pressure reaches the set-point, poppet valve assembly (D) and diaphragm (C) move upward closing seat area (E). Should downstream pressure exceed the desired regulated pressure, the excess pressure will cause the diaphragm (C) to move upward opening vent hole (K) venting the excess pressure to atmosphere through the hole in the bonnet (L). (This occurs in the standard relieving type filter/regulators only.)

Technical Information

CAUTION:

REGULATOR PRESSURE ADJUSTMENT - The working range of knob adjustment is designed to permit outlet pressures within their full range. Pressure adjustment beyond this range is also possible because the knob is not a limiting device. This is a common characteristic of most industrial regulators, and limiting devices may be obtained only by special design.

For best performance, regulated pressure should always be set by increasing the pressure up to the desired setting.

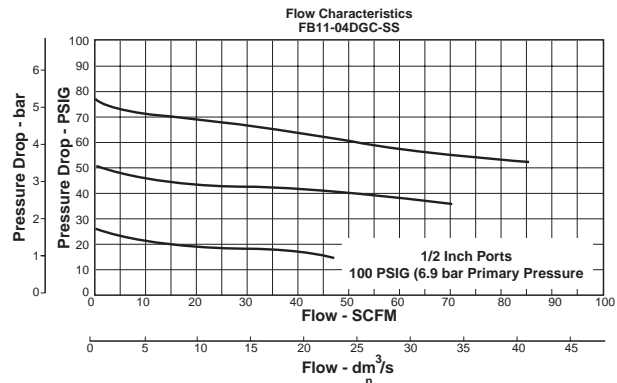

FB11 Regulator Kits & Accessories

FB11 Bonnet Kit (Knob Included)	CKR10YSS
Drain Kit -	
Automatic Float Drain	SA602MDSS
Manual Twist Drain	SA600Y7-1SS
Filter Element Kit -	
Particulate (5 Micron).....	EKF10VY
Gauge -	
160 PSIG (0 to 1100 kPa), 2" Face.....	K4520N14160SS
Panel Mount Bracket (Stainless).....	R10Y57-SS
Panel Mount Nut -	
Stainless	R10X51-SS
Plastic.....	R10X51-P
Service Kit -	
Relieving	RKR10YSS
Spring -	
0-125 PSIG Range	SPR-389-1-SS

Materials of Construction

Adjustment Mechanism / Springs	316 Stainless Steel
Body	316 Stainless Steel
Bonnet / Knob (B11)	Acetal
Bottom Plug	316 Stainless Steel
Poppet	316 Stainless Steel
Seals	Fluorocarbon
Sight Gauge	Isoplast

Specifications

Bowl Capacity	4.0 Ounces/114 ml
Filter Rating	5 Micron
Gauge Port	1/4 Inch
Operation	Fluorocarbon Diaphragm
Port Threads	1/2 Inch
Pressure & Temperature Ratings -	
Metal Bowl (D)	300 PSIG Max (20.7 bar) 0°F to 150°F (-18°C to 66°C)
Metal Bowl (W)	0 to 250 PSIG (0 to 17.2 bar) 0°F to 150°F (-18°C to 66°C)
Automatic Float Drain	15 to 175 PSIG (1 to 12 bar) 40°F to 125°F (4°C to 52°C)
Note: Air must be dry enough to avoid ice formation at temperatures below 32°F (2°C).	
Sump Capacity	1.7 Ounce
Weight	2.42 lb. (1.09 kg)

Compressed Air Filters

Automatic Drains - High and Normal Capacity

High Capacity Electric Solenoid Drain

The Balston Automatic Drain Assembly, P/N 20-440 automatically removes water from Balston filter housings. The autodrain consists of a solenoid valve and an automatic timer that can be adjusted to the desired cycle time and is powered by 120 VAC. To drain receiving tanks, use any commercially available Y-strainer (ex. Keystone 911 Series or Watts Model 7771) to protect the 20-440.



20-440



20-211

High Capacity Non-Electrical Float Drain

In the 20-211 design, a sealed stainless steel float operates a needle valve by means of a lever. All internal parts are stainless steel. The 20-211 drain is a rugged design for high volumes of liquid.

Normal Capacity Non-Electrical Float Drain

In the 20-402 design, a float rises to operate a pilot-controlled valve when the liquid level in the body of the drain reaches a predetermined level. The float is reset by the force of line pressure as soon as the liquid is drained.



20-402

Principal Specifications and Ordering Information

Model	20-211	20-440	20-402
Port Size	1/2" NPT	1/4" NPT	1/4" NPT
Maximum Pressure	440 psig (27.6 barg)	300 psig (20.7 barg)	200 psig (13.8 barg)
Minimum Pressure	10 psig (0.69 barg)	20 psig (1.4 barg)	40 psig (2.8 barg)
Maximum Temperature	500°F (260°C)	122°F (50°C)	130°F (54°C)
Shipping Weight	2 lbs. (0.9 kg)	2 lbs. (0.9 kg)	2 lbs. (0.9 kg)
Dimensions	2.5"W X 7.3"L (6cm X 19cm)	3"W X 4"L (7cm X 10cm)	3"W X 4L (7cm X 10cm)

Compressed Air Filters

Condensate Drains - Zero Air / Zero Energy Loss

Compressed Air Filters

What is a zero air loss condensate drain?





Zero air loss condensate drains are designed for economical removal of unwanted water, oil emulsions, and other liquids. These drains will only open when liquid is present and will not allow any compressed air to escape from the system.

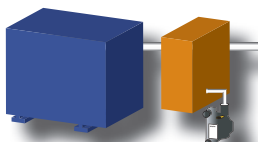

Why are they needed?

- Condensate is always present in a compressed air system.
- If condensate is not removed from a compressed air system, it will adversely affect product quality and production efficiency and will eventually lead to costly downtime.

Where are condensate drains used?

				
Compressor with Aftercooler	Receiver Tank	Filter	Air Dryer	Drip Leg
Removes the condensate that is collected after the air cools in the aftercooler	Removes the condensate that is collected when the air cools inside of the receiver tank	Removes the condensate that is collected in the filter bowl	Removes the condensate that is collected in the air dryer	Point-of-use applications: removes the condensate from compressed air pipes in a plant

How does the Zero Air Loss Condensate drain compare to other drains?

Condensate Removal Method	Disadvantages of Other Drains	Advantages of ZLD
Manual Drain (operators must manually open valves to discharge condensate)	<ul style="list-style-type: none"> • Requires constant attention • Always leads to excess air loss because air escapes when the valve is left open to drain the condensate 	<ul style="list-style-type: none"> • Automatically drains condensate • When a minimum level of condensate is reached, the valve closes in time before compressed air can escape
Float Drain (uses a float connected to a drain valve that opens when enough condensate is present and closes when condensate has been removed)	<ul style="list-style-type: none"> • Float is susceptible to blockage from particulate contamination in condensate • Often sticks in open (leaks excess air) or closed position (no condensate is drained) 	<ul style="list-style-type: none"> • Includes an integrated dirt screen between the level measurement and drain valve to protect the diaphragm valve • Particulate contamination is removed by the integrated dirt screen before fouling the moving parts
Solenoid Operated Drain Valves (uses a timer which allows user to open and close valve at specified intervals)	<ul style="list-style-type: none"> • The period for which the valve is open might not be long enough for adequate drainage of accumulated condensate • The valve will operate even if little or no condensate is present, resulting in air loss • Often requires a strainer to remove particulate contamination which can block the inlet and outlet ports 	<ul style="list-style-type: none"> • Drain will remove condensate when liquid reaches the high level sensor • The drain will not operate until the liquid level reaches the high level sensor • Particulate contamination is removed by the integrated dirt screen before fouling the outlet port

Compressed Air Filters

Condensate Drain - Zero Air / Zero Energy Loss

How does this drain work?

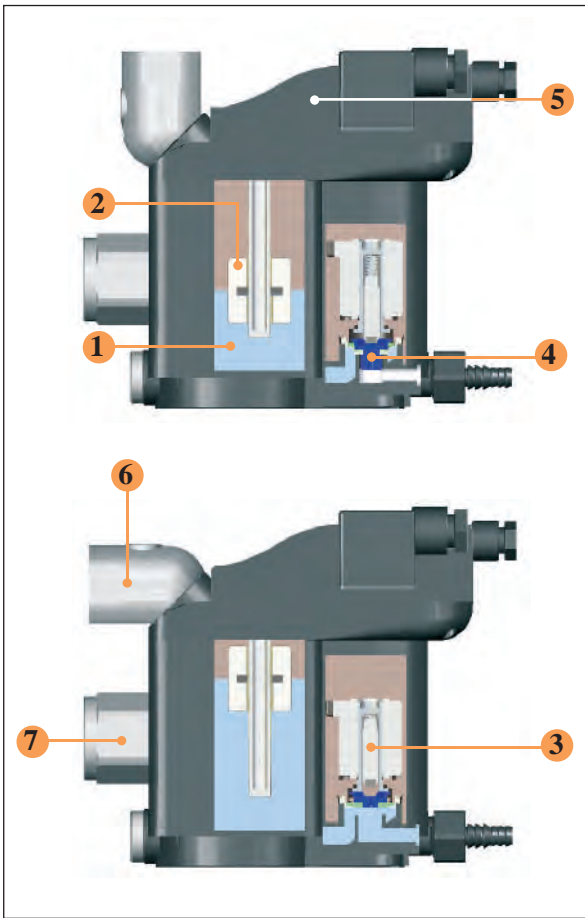

- 1 This collection vessel stores condensate until it is drained away.
- 2 This electronic level controller continuously monitors the liquid level inside the drain.
- 3 This depicts the electric drain valve. As soon as the electronic level controller detects a buildup of liquid, the valve opens and condensate is drained. When a minimum liquid level is reached, the valve closes before compressed air can escape.
- 4 The diaphragm valve ensures that contaminants are flushed out and that the condensate is prevented from forming an emulsion that would need expensive condensate treatment.
- 5 If an error has occurred (i.e. if the condensate cannot be discharged), the electronic control board (5) of the condensate drain generates an alarm signal. This allows timely detection of a problem and helps avoid excessive costs associated with condensate carryover to downstream components.
- 6 Unique swivel inlet connection for easy adaptability on 20-613 and 20-623. This allows the condensate line to be connected from the top or the rear. The 20-606 has a fixed inlet port with dynamic seal which allows the filter bowl to be removed while the drain is attached (not shown).
- 7 An additional liquid inlet on the 20-623 allows for the connection of a balance or vent line. This provides new connections so that condensate can no longer back up into the feed lines.

The cost of compressed air when using a timed drain valve

Annual Savings of a Zero Air Loss Drain
Versus Timed Solenoid Drain Valves

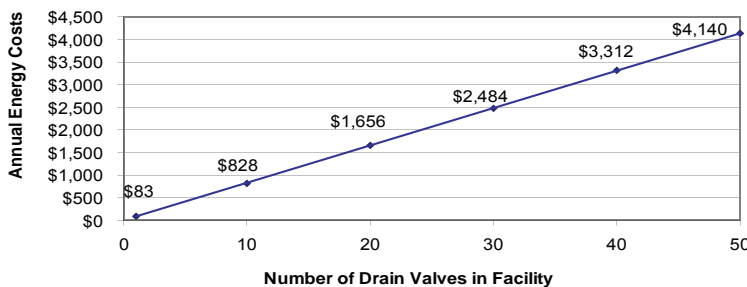

The annual cost of compressed air was calculated using data from the U.S. Department of Energy and several compressed air consultants. The average annual energy cost to maintain a compressed air system is \$0.23 per 1000 ft³. If a timed solenoid drain valve opens 3-4 times per hour, the cost of the wasted air will be \$80 per valve, per year.

Zero Loss Drains don't waste any compressed air and have a payback of approximately 6 months - 1 year.

**Easy
installation &
servicing!**

Compressed Air Filters

Condensate Drain - Zero Air / Zero Energy Loss

Compressed Air Filters

Dimensions and Specifications



20-606

Dimensions (Inches/cm)

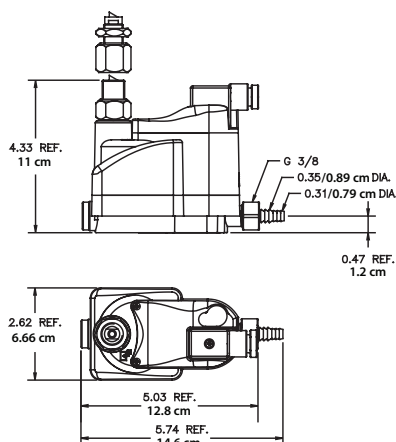

20-613

Dimensions (Inches/cm)

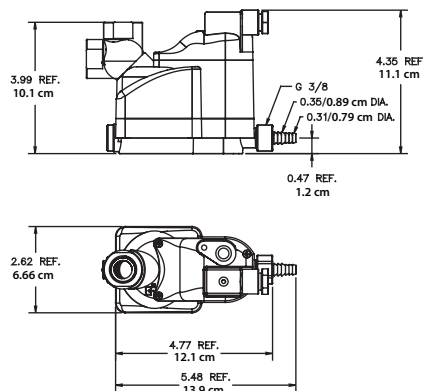

20-623

Dimensions (Inches/cm)

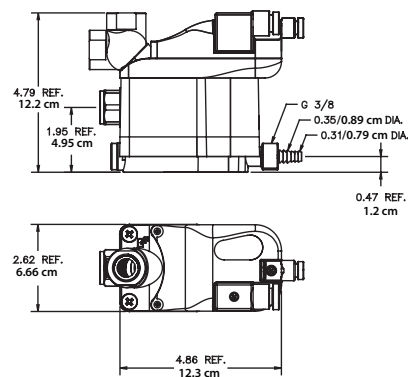

Model Number	Maximum Compressor Capacity	Maximum Refrigerated Dryer Capacity ¹	Maximum Filter Capacity ²	Pressure Range	Temperature Range	Connection Size	Drain Capacity	Electrical Requirement
20-606	Not Recommended	Not Recommended	424 SCFM (720 m ³ /h)	3 - 232 PSIG (0.2 - 16 bar)	35 -140°F (2 - 60 °C)	3/8" NPT	6 Gallons/23 liters per day	120V _{AC} (60Hz)
20-613	141 SCFM (240 m ³ /h)	283 SCFM (480 m ³ /h)	1413 SCFM (2,400 m ³ /h)	3 - 232 PSIG (0.2 - 16 bar)	35 -140°F (2 - 60 °C)	1/2" NPT	13 Gallons/49 liters per day	120V _{AC} (60Hz)
20-623	247 SCFM (420 m ³ /h)	494 SCFM (840 m ³ /h)	2472 SCFM (4,200 m ³ /h)	3 - 232 PSIG (0.2 - 16 bar)	35 -140°F (2 - 60 °C)	1/2" NPT	23 Gallons/87 liters per day	120V _{AC} (60Hz)

¹Based on 100 psi (6.9 bar) working pressure, air compressor inlet at 77°F (25°C) at 60% RH, air discharge temperature of 95°F (35°C) following the aftercooler, pressure dewpoint of 37°F (2.8°C) after the refrigerated dryer.

²Condensate from aftercooler or refrigerated dryer to be drained upstream – only for residual oil content or small quantities of condensate.

Note: Drains are available with BSP threads; 24V/50 - 60Hz versions are available; 24V DC on request. A 6 ft. (2 m) line cord will be included with each drain.

Compressed Air Filters

Differential Pressure Indicator Kit

Balston Differential Pressure Indicator

The Balston Differential Pressure Indicator (DPI) is used to monitor the pressure drop across the filters or other components in a compressed air system. The DPI is sensitive in the range of 0 to 5 psi differential.

Principal Specifications & Ordering Information

Model	41-070	C02-2377
Differential Pressure Indicator	41-070	C02-2377
Indicator and Installation Kit (1)	41-071	N/A
Port Size	1/8" NPT	3/8"-24
Maximum Pressure	250 psig (17.2 barg)	250 psig (17.2 barg)
Maximum Temperature	130°F (54°C)	130°F (54°C)
Dimensions	1.7"W X 1.8"H (4cm X 5cm)	2.9"W X 2.25"H (7cm X 6cm)

Note

1 Installation kit includes fittings and tubing necessary for line-mounting the 41-070 DPI



41-070



41-070 Mounted on Filter Assembly



C02-2377

Compressed Air Filters

Miniature Disposable Filter Units Constructed of Nylon and PVDF

Compressed Air Filters

Models 9922-05, 9933-05, 4433-05 and 9900-05

The 99XX-05 Models are the smallest Disposable Filter Units with 0.4 oz (11.7 ml) internal volume. These models are used in low flow gas or liquid sampling applications, such as liquids to specific-ion analyzers or gases to personal samplers. The Model 4433-05 has 1/4" and 3/8" barb connections molded into the inlet/outlet ports. The 9900-05 and 4433-05 are available with a color indicator that turns red when saturated with oil.

Models 9922-11 and 9933-11

Models 9922-11 and 9933-11 are used for applications similar to the smaller DFUs (Models 9922-05 and 9933-05) which require greater solids holding capacity and can tolerate the increased retention time.

Model 8833-11

These Disposable Filter Units are used as continuous coalescing filters with a third port serving as the drain, slip-stream, or by-pass port.



Model 99XX-05

Model 9922-05

Model 8833-11

Retention Efficiency

Model	Efficiency for 0.01 Micron Particles and Droplets
DX, DQ	93%
BX, BK, BQ	99.99%

Table 1

Flow Rates Air Flow at 2 psi (0.14 bar) drop, standard cu. ft. (normal cubic meters) per min. SCFM (Nm³/hr) at indicated line pressure

Filter Housing Type	Volume of Housing (CU. FT.)	Filter Tube Grade	Flow Rate (CFM) At 10" Water Press. Drop., 0 PSIG (barg)	Flow Rates (SCFM) at indicated line pressure							
				2 psig (0.14 barg)	20 psig (1.4 barg)	40 psig (2.8 barg)	60 psig (4.1 barg)	80 psig (5.5 barg)	100 psig (6.9 barg)	125 psig (8.6 barg)	
9900-05	0.0004	DQ	0.2 (0.23)	1.2 (1.40)	2.5 (2.92)	3.9 (2.56)	5.4 (6.32)	6.8 (7.96)	8.3 (9.71)	10.1 (11.82)	
9922-05		BQ/BK (1)	0.1 (0.12)	0.8 (0.94)	1.6 (1.87)	2.6 (3.04)	3.5 (4.09)	4.5 (5.26)	5.4 (6.32)	6.6 (7.72)	
9933-05			DX	0.4 (0.47)	1.8 (2.11)	3.6 (4.21)	6 (7.02)	8 (9.36)	10 (11.70)	12 (14.04)	14.6 (17.08)
4433-05				BX	0.2 (0.23)	0.9 (1.05)	1.8 (2.11)	3 (3.51)	4 (4.68)	5 (5.85)	6 (7.02)

¹ BK = Red color indicator when saturated with oil.

Installation Information

Compression fittings for 1/4" O.D. tubing may be obtained from the following manufacturers: Hoke, Inc. (Gyrolock); Crawford Fitting Co. (Swagelok); Parker-Hannifin Corp. (CPI); Legris, Inc. (push-on fittings); Jaco Mfg. Co. (plastic fittings).

The following brass fittings seal by O-ring compression and may be completely recovered and reused when changing filters. They may be purchased from Parker Hannifin Corp.

Connector 1/4" tubing to 1/4" NPT, female - P/N 11970

Connector 1/4" tubing to 1/4" tubing - P/N 11971

Elbow 1/4" tubing to 1/8" NPT female (for manual drain on Type 8833-11) - P/N 11972

For connections to low pressure plastic tubing

Tubing with 1/4" ID may be slipped over the DFU end fittings and held with tubing clamps. Parker Hannifin Corp. supplies plastic barbs to connect the DFU to smaller diameter plastic tubing. The connection is suitable for pressures to 50 psig.

DFU to 1/16" ID tubing P/N 14000 (bag of 20 barbs)

DFU to 1/8" ID tubing P/N 14001 (bag of 20 barbs)

Parker Hannifin Corp. also offers a manual drain valve for removal of coalesced liquids from the Type 8833-11-DX

Drain Valve 1/8" NPT (male) x 1/8" ID tubing (requires fitting part 11977) P/N 20120

Compressed Air Filters

Miniature Disposable Filter Units Constructed of Nylon and PVDF

Principal Specifications

Model	9922-05	9900-05, 9933-05	4433-05	9922-11	9933-11	8833-11
Inlet and Outlet Ports	1/4" Tubing	1/4" Tubing	1st Tier/Barb 1/4" Tube 2nd Tier/Barb 3/8" Tube	1/4" Tubing	1/4" Tubing	1/4" Tubing
Drain	None	None	None	None	None	1/4" Tubing
Material of Construction	PVDF	Nylon	Nylon	PVDF	Nylon	Nylon
Filter Cartridge Length	1.25" (3.2 cm)	1.25" (3.2 cm)	1.25" (3.2 cm)	2.25" (5.7 cm)	2.25" (5.7 cm)	2 1/4"
Maximum Temperature	275°F (135°C) (1)	230°F (110°C) (1)	230°F (110°C) (1)	275°F (135°C) (1)	230°F (110°C) (1)	230°F (110°C) (1)
Maximum Pressure	125 psig/8.62 barg (2)	125 psig/8.62 barg (2)	125 psig/8.62 barg (2)	125 psig/8.62 barg (2)	125 psig/8.62 barg (2)	125 psig/8.62 barg (2)
Dimensions	1.0"D X 3.25"L (2.5 cm X 6 cm)	1.0"D X 3.25"L (2.5 cm X 6 cm)	1.0"D X 3.43"L (2.5 cm X 8.72 cm)	1.4"D X 4.6"L (9.1 cm X 12 cm)	1.4"D X 4.6"L (9.1cm X 12 cm)	1.4"D X 4.6"L (9.1 cm X 12 cm)

Ordering Information

For assistance, call toll-free at 1-800-343-4048 8AM to 5PM Eastern Time

Model	9922-05	9900-05	4433-05	9933-05	9922-11	9933-11	8833-11
Filter Cartridges Box of 10 Available in types Q and X	9922-05-□ (3)	9900-05-□ (3)	4433-05-□ (3)	9933-05-□ (3)	9922-11-□ (3)	9933-11-□ (3)	8833-11-□ (3)

Notes:

1 At 0 psig

2 At 110°F (43°C)

3 To designate the grade of filter tube in the DFU, insert Grade letters after DFU designation. For example, to obtain a grade BQ filter tube in a DFU 9922-05, order: 9922-05-BQ. Please note the following limitations:

DFU	Supplied With These Grades
4433-05, 9900-05, 9922-05, 9933-05	DQ, BQ, AQ (BK) (4)
9922-11, 9933-11	DX, BX, AQ
8822-11, 8833-11	DX, BX

4 BK Grade has a color indicating feature, which turns the cartridge red when saturated with oil. Available only in types 4433-05 and 9900-05.

Application Notes

 State of California ONLY
WARNING: Proposition 65
The products described herein can expose you to chemicals known to the State of California to cause cancer or reproductive harm.
For more information: www.P65Warnings.ca.gov